

Silentbloc®

Vibration Solutions 2017-2018 Catalogue



Motherson Elastomers Pty Limited

Proud to be part of samvardhana **motherson**



Customer Service

48-86, Powell Street
Bendigo, Victoria, 3550, Australia
PH: +61 3 5440 2069
Fax: +61 3 5443 1661

HEAD OFFICE

Unit 4, 18-22, Lexia Place
Mulgrave, Victoria, 3170 Australia
PH: +61 3 8561 7900
Fax: +61 3 8561 7999

ABN: 19 124 112 009

ACN: 124 112 009

Contents

	Stud Mounts _____ 8		Low Deflection Flange Mounts Medium Duty _____ 30
	Buffer Mounts _____ 12		Suspension Isolators Medium Duty _____ 31 Heavy Duty _____ 32
	Pedestal Mounts Light Duty _____ 13		Side Attachment Mounts _____ 33
	Medium Deflection Frustacon Medium Load _____ 14 High Load _____ 15		Machine Level Mounts _____ 34
	High Deflection Frustex Medium Load _____ 16		Industrial Bearings _____ 37
	High Deflection Frustex High Load _____ 17		Shear Compression Mounts Plate Isolators _____ 52
	Low Deflection Mounts Medium Duty _____ 18		Hyflex Flexible Couplings _____ 54
	Low Deflection Mounts Heavy Duty _____ 20		Wheel Chocks & Hose Ramps _____ 65
	Medium Deflection Flange Mount Frustacon Medium Load _____ 26		Vibration Control Pads _____ 66
	Medium Deflection Flange Mount Frustacon High Load _____ 27		Rubber Extrusions _____ 67
	High Deflection Flange Mount Frustex Medium Load _____ 28 High Load _____ 29		Injection & Compression Moulding _____ 68

Index

Product Applications	6
Isolation Nomogram	7
➤ How to Use the Nomogram	7
➤ Example	7
Stud Mounts	8
➤ Design Variations	8
➤ Silentbloc Rubber Mount unique features	8
➤ Tolerances	9
Buffer	12
Pedestal Mounts	13
➤ Light Duty	13
➤ Tolerances	13
➤ Medium Deflection Frustacon – Medium Load	14
➤ Tolerances	14
➤ Medium Deflection Frustacon – High Load	15
➤ Tolerances	15
➤ High Deflection Frustex – Medium Load	16
➤ Tolerances	16
➤ High Deflection Frustex – High Load	17
➤ Tolerances	17
➤ Low Deflection – Medium Duty	18
➤ Tolerances	19
➤ Protective Covers	19
➤ Low Deflection – Heavy Duty	20
➤ Tolerances	20
➤ Protective Covers	20
Frustex Pedestal & Flange Mounts	21
➤ NF1000 & NF2000 Series	21
➤ NP1000 Series	23
➤ NF & NP Series Load Deflection Curves	24
Flange Mounts	26
➤ Medium Deflection Frustacon – Medium Load	26
➤ Tolerances	26
➤ Medium Deflection Frustacon – High Load	27
➤ Tolerances	27
➤ High Deflection Frustex – Medium Load	28
➤ Tolerances	28
➤ High Deflection Frustex – High Load	29
➤ Tolerances	29
➤ Low Deflection – Medium Duty	30
➤ Tolerances	30

Suspension Isolators	31
➤ Medium Duty	31
➤ Tolerances	31
➤ Heavy Duty	32
➤ Tolerances	32
Side Attachment Mounts.....	33
➤ Tolerances	33
Machine Levelmounts.....	34
Movable Mounts	36
➤ Medium Deflection Frustacon – Medium Load	36
➤ Tolerances	36
Industrial Bearings	37
➤ Standard Industrial Range.....	37
➤ High Axial Load Range	41
➤ Bonded Range.....	42
➤ Loading Types & Ratings	43
➤ Radial Loading.....	43
➤ Conical Loading.....	43
➤ Axial Loading	43
➤ Torsional Loading.....	43
➤ Combination Loading	43
➤ Installation Notes	44
➤ Bearing Tolerances	44
➤ Housing Fits	45
Flexible Ball Joints.....	46
➤ Parallel Bore	46
➤ Tapered Bore.....	47
➤ Solid Extended Pin Parallel Face.....	48
➤ Solid Extended Pin Tapered Face.....	49
➤ Fitted Pin.....	50
Link Assemblies	51
Shear - Compression Mounts / Plate Isolators	52
➤ Tolerances	53
Hyflex Flexible Couplings	54
➤ Patented Universal Coupling Bush.....	54
➤ Selection Procedure	55
➤ Speed Change Devices.....	55
➤ Axial Thrust	56
➤ Maximum Speed.....	56
➤ Bore Dimension and Tolerances.....	56
➤ Fitting and Alignment.....	57

➤ Service Factors.....	58
➤ Coupling Dimensions	59
➤ Capacities.....	61
Wheel Chocks & Hose Ramps	65
Vibration Control Pads	66
Rubber Extrusions	67
Moulding Capabilities	68

Product Applications

	Stud Mounts & Light Duty Pedestal Mounts	Medium Deflection Frustacon	High Deflection Frustex	Heavy Duty Pedestal Mounts	Low Deflection Medium Duty Mounts	Shear-Compression Mounts	Machine Levelmounts	Vibration Control Pads	Suspension Isolators	Flexible Bearings	Wheel Chocks
Engines		X	X	X	X	X				X	
Generators	X	X	X	X	X	X					
Compressors	X	X	X	X	X						
Fans and Blowers	X	X	X	X	X			X			
Air Conditioning Equipment	X	X	X	X	X	X		X			
Motors	X	X	X	X	X	X		X			
Pumps	X	X	X	X	X	X					
Conveyors										X	
Agitators & Mixers	X	X	X	X	X	X		X			
Machine Tools							X				
Power Presses							X				
Plastics Moulding Machines							X				X
Woodworking Machines							X				
Mills		X	X	X	X	X					X
Guillotines							X				X
Crushing Machines		X	X	X	X	X					
Suspended Ceilings & Pipe Work									X		
Tractor Cabs	X	X	X	X	X	X					
Agricultural Equipment	X	X	X	X	X	X					
Vehicle Suspension					X					X	
Truck Bodies		X			X						
Refrigeration Units	X	X									
Cold Heading Machines		X	X								
Electronic Equipment	X	X	X								
Vehicles											X

Isolation Nomogram

➤ How to Use the Nomogram

Place a ruler across the page such that its edge is at a known value on any two scales; along the same edge simply read off equivalent values on the other scale.

➤ Example

Forcing frequency (ie: vibration frequency) is known to be 800 cycles per minute in a particular application, and isolation of 70% is desired. On the right hand scale, the same edge intersects the left hand scale at the 6.0mm mark therefore a minimum deflection of 6.0mm is required to achieve the desired 70% isolation.

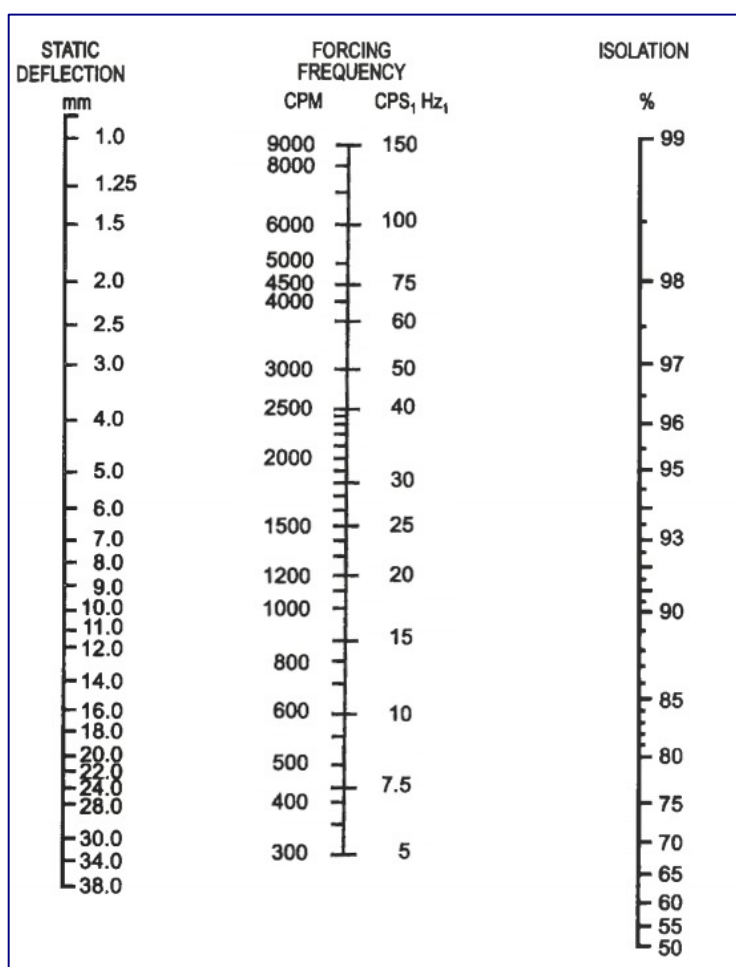

Figure 1: Isolation nomogram

Note

Vibration transmission is conditioned by many factors beyond the scope of this simplified nomogram. Isolation percentages shown are indicative only.

Stud Mounts

The simplest form of vibration control mounting, comprising a rubber component bonded either end to a threaded metal stud. It is intended for use in shear or compression, and is not recommended for permanent tension loading. It may be used for mounting instrument packages and many types of light machinery, as a panel isolator, or to provide lateral restraint for equipment carried on other types of mounting.

➤ **Design Variations**

Variations to thread length, type and internally threaded mounts can be manufactured on request. Minimum quantities may apply.

➤ **Silentbloc Rubber Mount unique features**

- Excellent bonding between rubber and metal
- All metal parts zinc plated
- High quality natural rubber
- Nuts supplied with each mount



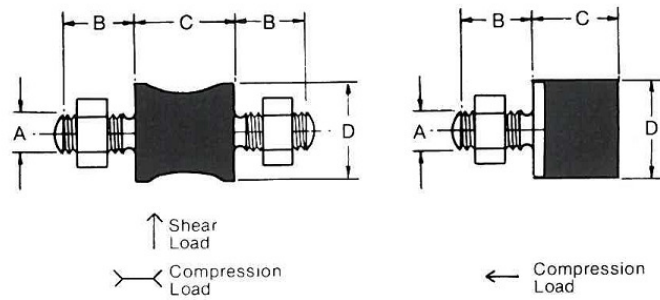

Double Stud	Dimensions (mm)				Compression		Shear	
	A	B	C	D	Normal Load (kg)	Deflection (mm)	Normal Load (kg)	Deflection (mm)
B134	M6x1.00	12	16	16	6.8	1.5	2.7	3.3
B138	M6x1.00	12	16	22	10.5	1.5	5.5	4.3
B241	M8x1.25	24	25	32	15.0	2.5	10.9	5.1
AB100	M10x1.50	24	35	40	45	2.5	18	5.0
AM445	M10x1.50	23	39	73	270	4.0	90	8.0
Single Stud	A	B	C	D	Normal Load (kg)	Deflection (mm)		
AB200	M6x1.00	12	13	16	6.8	1.5		
AB201	M6x1.00	12	13	22	10.5	1.5		
AB203	M8x1.25	24	22	32	15.0	2.5		
AB204	M10x1.50	24	32	40	45	2.5		

➤ Tolerances

Usual acceptable working range of the mounting is 60% to 110% of the normal load. Approximate deflections at loads other than normal can be approximated on a ratio basis. Tolerance on deflection is $\pm 20\%$.

Female Stud Mounts

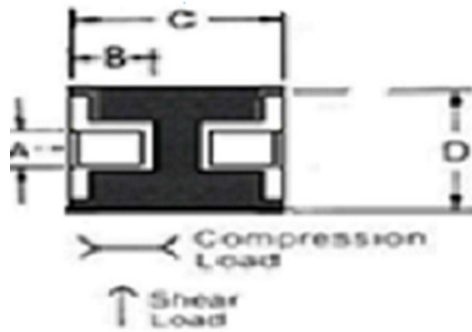

Female Studs	Dimensions (mm)				Compression		Shear	
	A	B	C	D	Normal Load	Deflection (mm)	Normal Load	Deflection (mm)
B241-0808-FF-40	M8x1.25	8	25	32	102	4	10.9	5.1
B241-0808-FF-60	M8x1.25	8	25	32	160	4	19.8	5.1
B241-0808-FF-70	M8x1.25	8	25	32	200	4	36.3	5.1
AB100-1010-FF-40	M10x1.5	12	35	40	152	6	23	6
AB100-1010-FF-60	M10x1.5	12	35	40	245	6	37	6
AB100-1010-FF-70	M10x1.5	12	35	40	272	6	44	6
AM445-1212-FF-75	M12x1.7	14	39	73	270	4	90	8
MCI186-FF -40	M6x1.00	5.5	25	20	27	6	4.5	6
MCI186-FF -60	M6x1.00	5.5	25	20	65	6	11	6
MCI186-FF -70	M6x1.00	5.5	25	20	76	6	12.8	6
MCI50-1212-FF-75	M12x1.7	18	40	50	190	1.5	45	5

➤ Tolerances

Usual acceptable working range of the mounting is 60% to 110% of the normal load. Approximate deflections at loads other than normal can be approximated on a ratio basis. Tolerance on deflection is $\pm 20\%$.

HYBRID B241 STUD MOUNTS

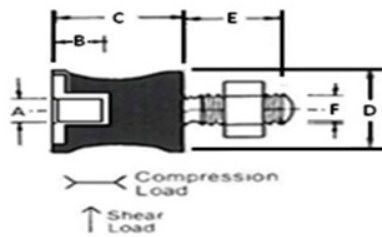

HYBRID AB100 STUD MOUNTS

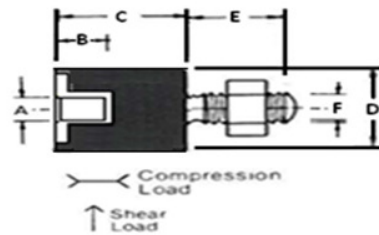

Hybrid Studs	Dimensions						Compression		Shear	
	A	B	C	D	E	F	Normal Load (kg)	Deflection (mm)	Normal Load (kg)	Deflection (mm)
B241-0808-FM-40	M8x1.	8	25	32	25	M8x1.	76	5.5	10.9	5.1
B241-0808-FM-60	M8x1.	8	25	32	25	M8x1.	102	5.5	19.8	5.1
B241-0808-FM-70	M8x1.	8	25	32	25	M8x1.	125	5.5	36.3	5.1
AB100-1010-FM-40	M10x1	12	35	40	35	M10x1	78	5.5	13	5
AB100-0808-FM-60	M10x1	12	35	40	35	M10x1	100	5.5	17	5
AB100-0808-FM-70	M10x1	12	35	40	35	M10x1	120	5.5	21	5

➤ Tolerances

Usual acceptable working range of the mounting is 60% to 110% of the normal load. Approximate deflections at loads other than normal can be approximated on a ratio basis. Tolerance on deflection is $\pm 20\%$.

Buffer

An effective, easy to install mounting that controls noise, reduces vibration and lessens the effect of impact. The AB206 is ideally suited for use as a snubber in situations where flexibly mounted equipment needs to be restrained from lateral movement. Can also be used as a simple foot mounting for machinery and many different types of equipment.

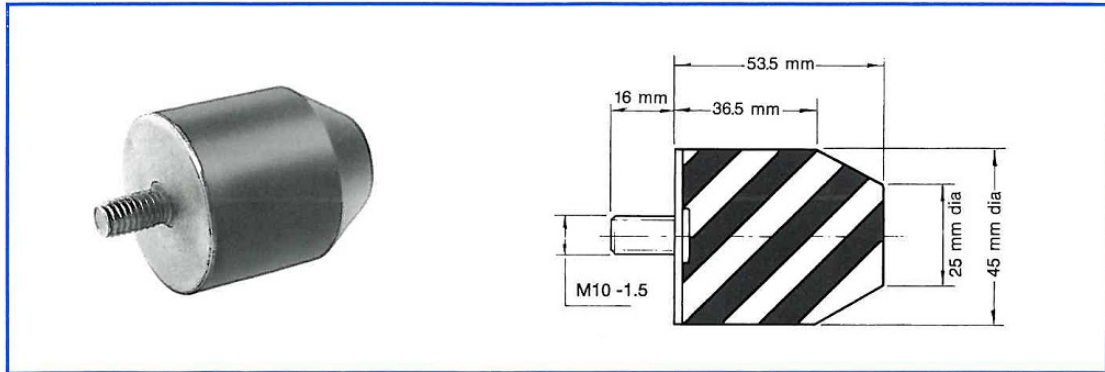

Part #	Static Load (kg)	Deflection (mm)	Buffing/Impact Load (kg)	Deflection (mm)
AB206	75	10	125	15

Pedestal Mounts

➤ Light Duty

A compact, robust rubber-in-shear mounting suitable for light loads.

Features include security against excessive overload and rebound movement, corrosion protection, base design to suit variety of fixing methods, and hexagon headed tapped inner sleeve.

All types have identical physical dimensions; the different load characteristics are achieved through altered rubber hardness.

These mounts are well suited for mounting equipment such as compressors, generators, small motors and fans.

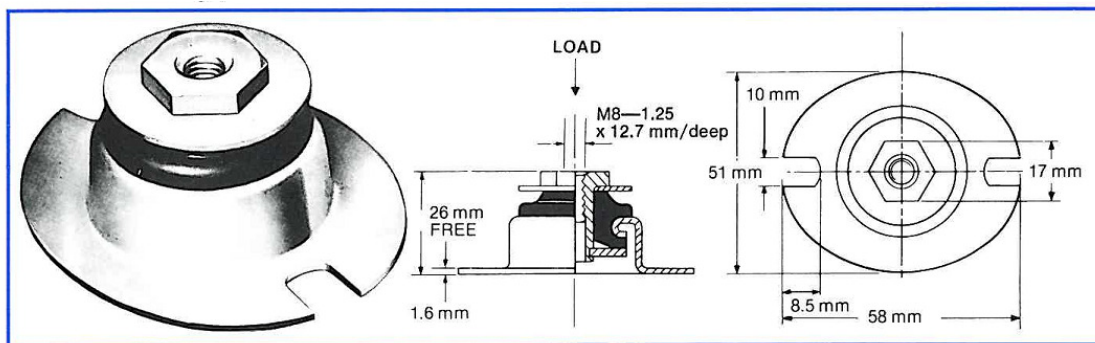

Part #	Normal Load (kg)	Deflection (mm)
FN1610	4.5	1.6
FN1620	9.0	1.6
FN1630	13.6	1.6
FN1645	20.5	1.6
FN1660	27.3	1.6

➤ Tolerances

Usual acceptable working range of the mounting is 60% to 110% of the normal load. Approximate deflections at loads other than normal can be approximated on a ratio basis. Tolerance on deflection is $\pm 20\%$.



➤ **Medium Deflection Frustacon – Medium Load**

The Frustacon pedestal mounting combines excellent isolation characteristics with convenient installation features.

Design features include security against excessive overload and rebound movement, a protective steel cover and an attractive light weight aluminium base.

This particular mount is suitable for a large variety of installations. It is typically employed for mounting pumps, compressors, fans and general purpose machines in static and some mobile applications.

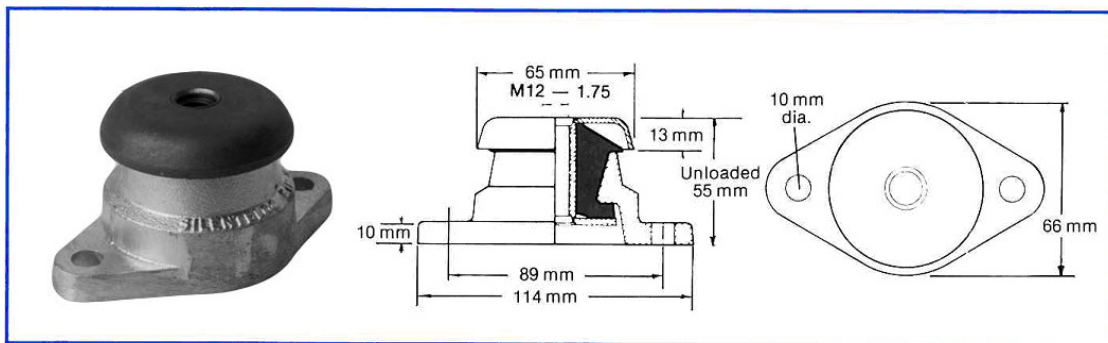

Part #	Normal Load (kg)	Deflection (mm)
FAP	90	6.4
FBP	180	6.4

➤ **Tolerances**

Usual acceptable working range of the mounting is 60% to 110% of the normal load. Approximate deflections at loads other than normal can be approximated on a ratio basis. Tolerance on deflection is $\pm 20\%$.



➤ Medium Deflection Frustacon – High Load

The Frustacon pedestal mounting combines excellent isolation characteristics with convenient installation features.

Design features include security against excessive overload and rebound movement, a protective steel cover and an attractive light weight aluminium base.

This particular mount is suitable for a large variety of installations. It is typically employed for mounting pumps, compressors, fans and general purpose machines in static and some mobile applications.

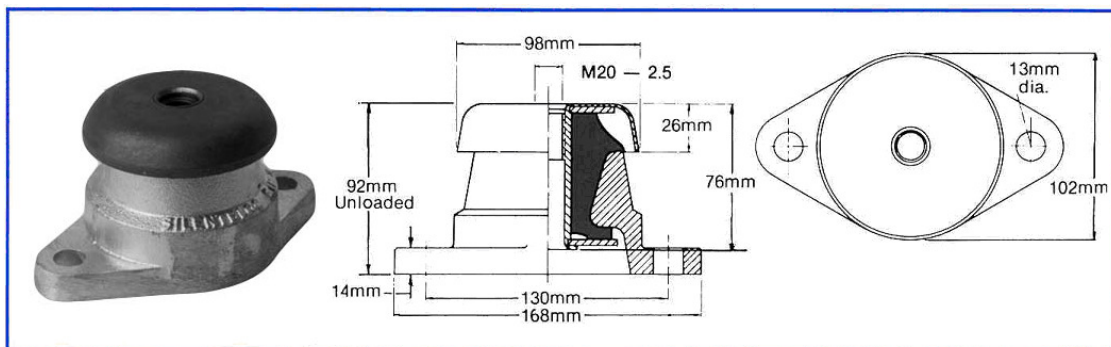

Part #	Normal Load (kg)	Deflection (mm)
FDP	300	6.0
FEP	600	6.0

➤ Tolerances

Usual acceptable working range of the mounting is 60% to 110% of the normal load. Approximate deflections at loads other than normal can be approximated on a ratio basis. Tolerance on deflection is $\pm 20\%$.

➤ High Deflection Frustex – Medium Load

Frustex pedestal mountings give very high flexibility.

Outstanding design features include security against excessive overload and rebound movement, enveloping pressed steel protective cover, impact proof lightweight cast aluminium pedestal, and high load capacity.

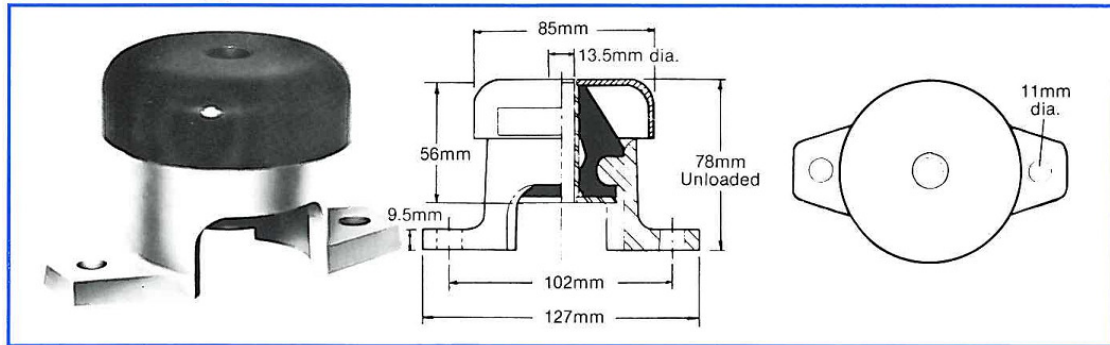

Part #	Normal Load (kg)	Deflection (mm)
FXBP	180	12.7
FXCP	270	12.7

➤ Tolerances

Usual acceptable working range of the mounting is 60% to 110% of the normal load. Approximate deflections at loads other than normal can be approximated on a ratio basis. Tolerance on deflection is $\pm 20\%$.



➤ High Deflection Frustex – High Load

Designed for supporting heavier equipment to isolate disturbances above 480 CPM. Machinery is attached to the mounting by an M20 bolt which screws into the rebound washer, pulling it up against the inner tube. This washer limits movement by bearing against the bottom of the rubber. It can be used either way up, depending on the amount of loading and the movement limitation required. Pedestal and inner are of aluminium.

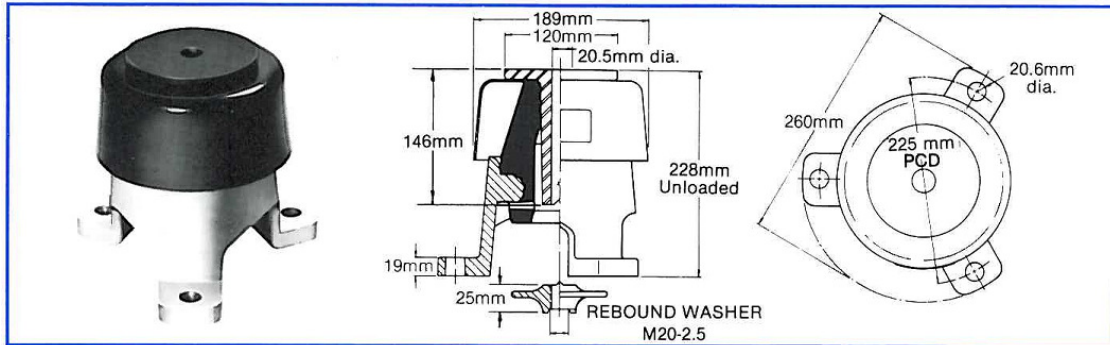

Part #	Normal Load (kg)	Deflection (mm)	Rebound Washer Preload (mm)	
			As Shown	Reversed
FXDP	800	20	10	5
FXEP	1300	20	10	5

➤ Tolerances

Usual acceptable working range of the mounting is 60% to 110% of the normal load. Approximate deflections at loads other than normal can be approximated on a ratio basis. Tolerance on deflection is $\pm 20\%$.



➤ Low Deflection – Medium Duty

A general application mounting based on the Silentbloc principle of mechanically assembled pre-stretched rubber. These mountings are robustly constructed, and incorporate integral protection against excessive rebound movement. They are particularly suited for applications where lateral movement of installed equipment must be minimised.

Fail safe mountings suitable for marine, rail and off road applications.

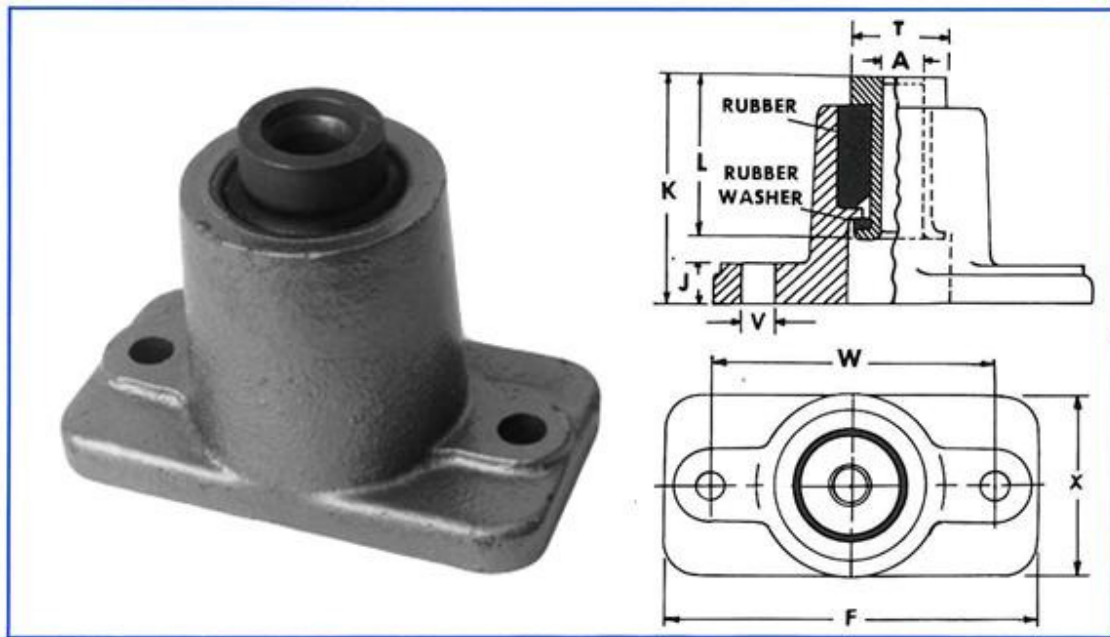

Part #	Dimensions (mm)									Compression	
	A	F	J	K	L	T	V	W	X	Normal Load (kg)	Deflection (mm)
J11P	8.0	67	6.0	41	29.5	16.0	7.2	51	32	7	1.0
J41P										20	0.9
P46P	9.8	97	12.5	65	43.0	24.0	11.0	70	46	23	1.8
P16P										36	1.3
S48P	12.7	118	16.0	75	51.0	28.5	12.7	89	58	45	3.3
S22P										80	2.5
R11P	16.1	135	17.0	93	63.5	39.0	14.0	101	72	110	3.8
R78P										200	2.0
M45P	19.3	154	19.0	110	78.0	41.0	14.0	121	83	200	4.6
M83P										340	3.3
H26P	22.5	186	19.0	136	104.0	60.5	17.5	146	102	450	5.6
H75P										680	3.0

➤ Tolerances

Usual acceptable working range of the mounting is 60% to 110% of the normal load. Approximate deflections at loads other than normal can be approximated on a ratio basis. Tolerance on deflection is $\pm 20\%$.

➤ Protective Covers

Protective covers are recommended to protect the rubber from excessive oil, strong direct sunlight, or possible physical damage.

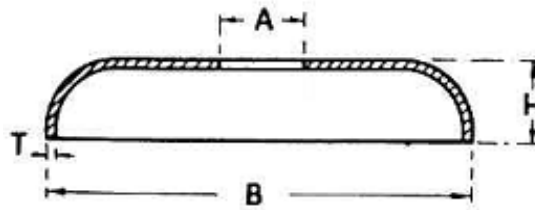

Cover Type	Dimensions (mm)			
	A	B	H	T
SOS	13.5	63.5	9.5	0.9
ROS	16.7	76.2	12.7	0.9
MOS	19.9	95.3	15.9	0.9
HOS	23.0	114.3	19.1	1.2

Note: Covers are not available for J and P types

➤ Low Deflection – Heavy Duty

A robust mounting for large machines requiring point support for up to 2.3 tonnes.

For mobile installations and machines with substantial rebound movement, separate rebound restraint may be required; refer Silentbloc for recommendations. Protective covers are recommended to protect the rubber from excessive oil, strong direct sunlight, or possible physical damage.

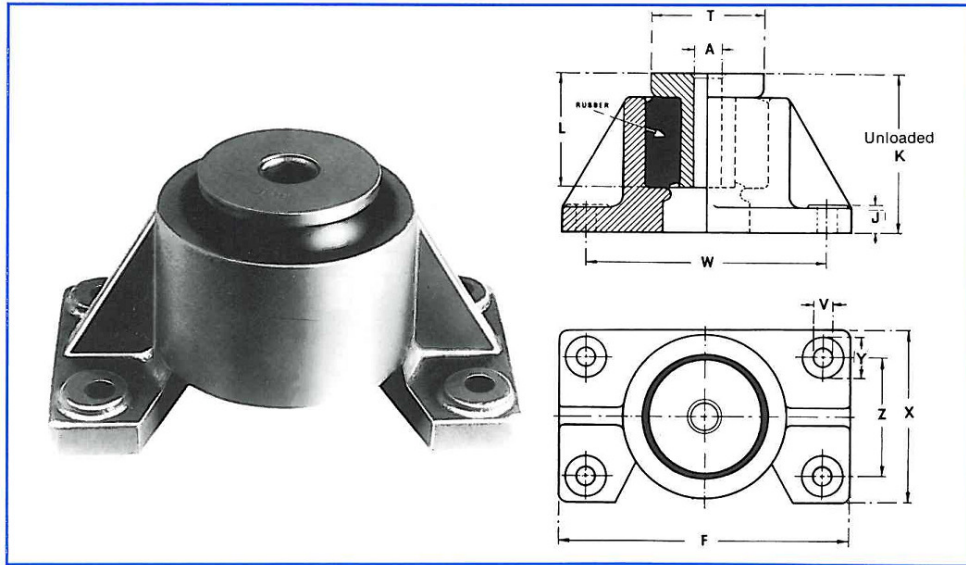

Part #	Dimensions (mm)											Compression		
	A	F	J	K	L	T	V	W	X	Y	Z	Normal Load (kg)	Deflection (mm)	Max Load (kg)
W30	29.5	204	23.5	140	102	90	16.6	165	147	38	108	680	6.4	910
W34												910	6.4	1140
V08	32.5	308	34	166	111	115	20	248	178	44	121	1360	10.2	1820
V01												1820	10.2	2270

➤ Tolerances

Usual acceptable working range of the mounting is 60% to 110% of the normal load. Approximate deflections at loads other than normal can be approximated on a ratio basis. Tolerance on deflection is $\pm 20\%$.

➤ Protective Covers

Protective covers are recommended to protect the rubber from excessive oil, strong direct sunlight, or possible physical damage.

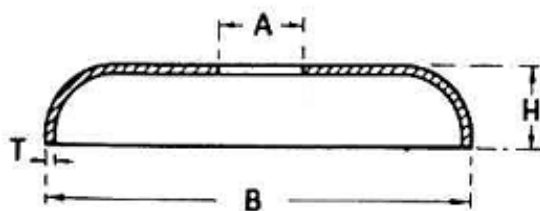

Cover Type	Dimensions (mm)			
	A	B	H	T
WOS	30	153	19	1.2
VOS	33	203	25	1.2

Frustex Pedestal & Flange Mounts

➤ **NF1000 & NF2000 Series**

The Frustex NF1000 Series mounting provides a good degree of flexibility and has a vertical/transverse stiffness ratio of 1:1.

The Frustex NF2000 Series mounting is very flexible with a vertical/transverse stiffness ratio of 4:1.

The NF type mounting has a flange type fixing arrangement, which has a two-bolt fitting. This fixing arrangement is suitable for fitting on narrow metal structures or where a height saving is required.

The mounting, which has a single bolt connection to the supported equipment, may be used in the inverted position.

For load/deflection characteristics refer to the load/deflection curves.

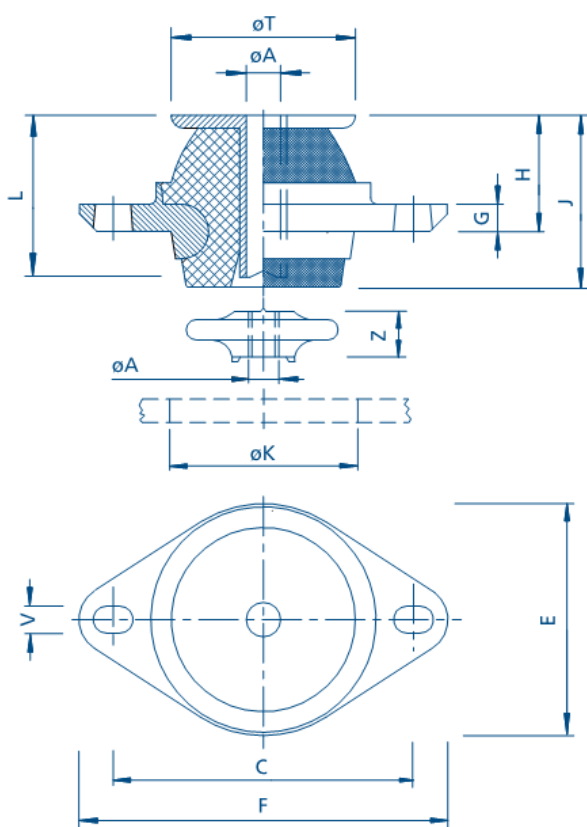

Figure 2: NF1000 Series

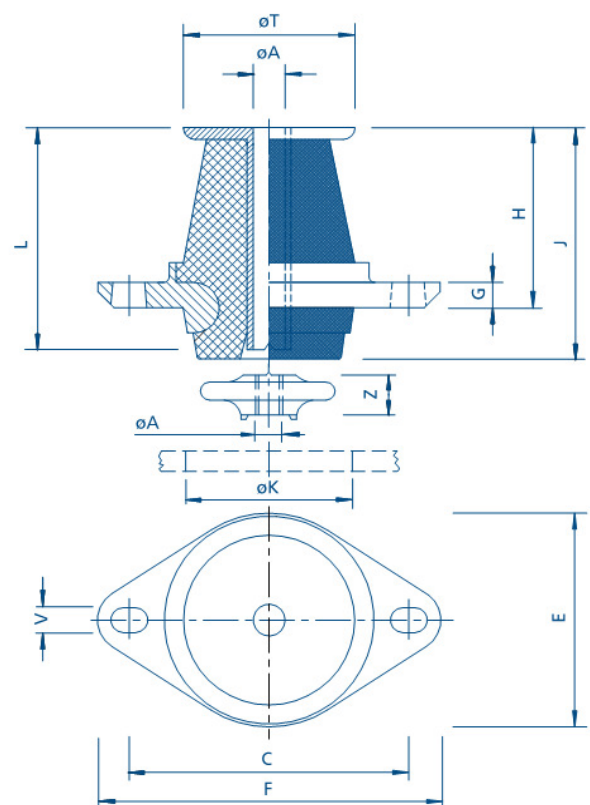

Figure 3: NF2000 Series

* Not a stock item – long lead times may apply

Part #	Dimensions (mm unless noted)													
	A (Metric)	A (Imperial)	C	E	F	G	H	J	K	L	T	V (Metric)	V (Imperial)	Z
NF1144*	6	1/4"	78	81	100	7	30	41	44	39.7	43	M8	5/16"	9
NF1145*														
NF1147*														
NF1244*	10	3/8"	102	78	127	9.5	41	57	60	55.5	60	M10	3/8"	12.5
NF1245*														
NF1247*														
NF1344*	16	5/8"	140	108	171	12.5	54	79	86	76	86	M12	1/2"	17.5
NF1345*														
NF1347*														
NF1444*	20	3/4"	200	155	245	17.5	78	113	120	105	120	M20	3/4"	25.5
NF1445*														
NF1447*														
NF1544*	26	1"	270	216	320	25.5	108	159	165	151	172	M22	7/8"	35
NF1545*														
NF1547*														
NF2144*	6	1/4"	78	81	100	7	48	58	44	51	43	M8	5/16"	9
NF2145*														
NF2147*														
NF2244*	10	3/8"	102	78	127	9.5	67	84	60	73	60	M10	3/8"	12.5
NF2245*														
NF2247*														
NF2344*	16	5/8"	140	108	171	12.5	90	114	86	102	86	M12	1/2"	17.5
NF2345*														
NF2347*														
NF2444*	20	3/4"	200	155	245	17.5	127	162	120	144	120	M20	3/4"	25.5
NF2445*														
NF2447*														
NF2544*	26	1"	270	216	320	25.5	179	230	165	202	172	M22	7/8"	35
NF2545*														
NF2547*														

* Not a stock item – long lead times may apply

➤ NP1000 Series

The Frustex NP1000 Series mounting provides a good degree of flexibility and has a vertical/transverse stiffness ratio of 1:1.

The NP type mounting has a pedestal fixing arrangement, which provides a three-point base support.

The mounting, which has a single bolt connection to the supported equipment, may be used in the inverted position.

For load/deflection characteristics refer to the load/deflection curves.

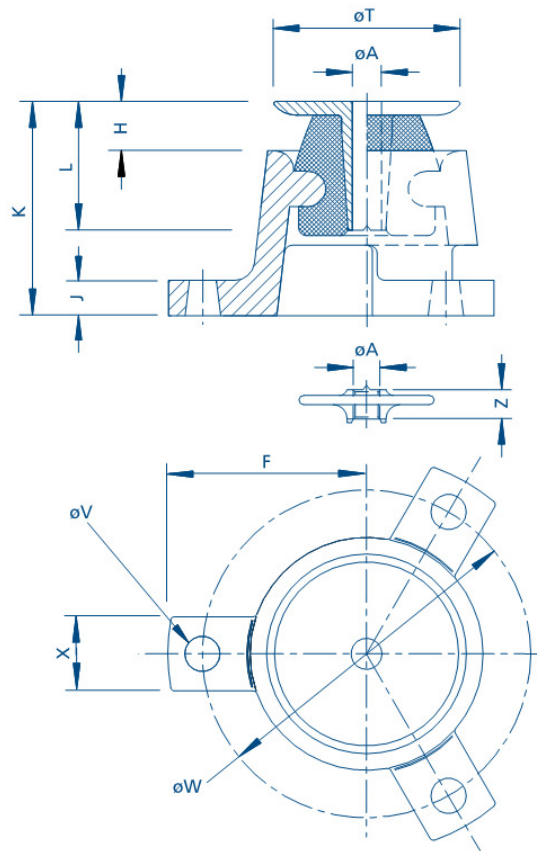

Figure 4: NP1000 Series

Part #	Dimensions (mm unless noted)												
	A (Metric)	A (Imperial)	F	H	J	K	L	T	V (Metric)	V (Imperial)	W	X	Z
NP1244*	M10	3/8"	65	22	9	86	55	60	M10	3/8"	111	28	13
NP1245*													
NP1247*													
NP1344*	M16	5/8"	95	32	13	122	76	86	M12	1/2"	155	41	17
NP1345*													
NP1347*													

* Not a stock item – long lead times may apply

➤ NF & NP Series Load Deflection Curves

Figure 5: NF1100 Series Load Deflection

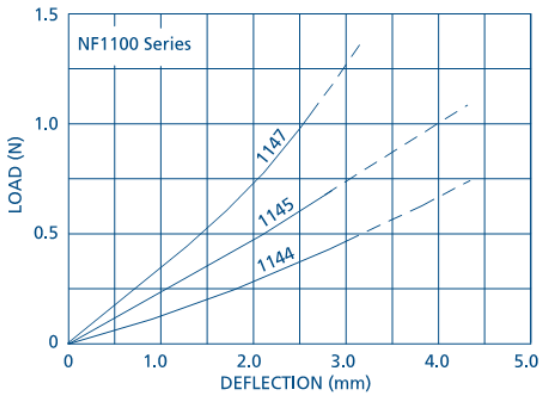

Figure 6: NF & NP1200 Series Load Deflection

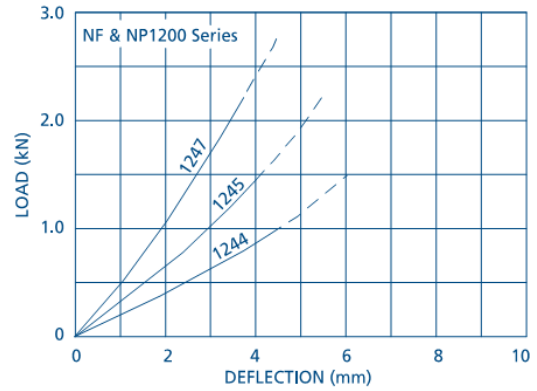

Figure 7: NF & NP1300 Series Load Deflection

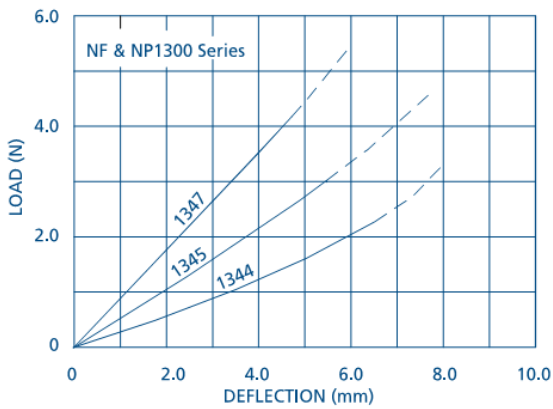

Figure 8: NF1400 Series Load Deflection

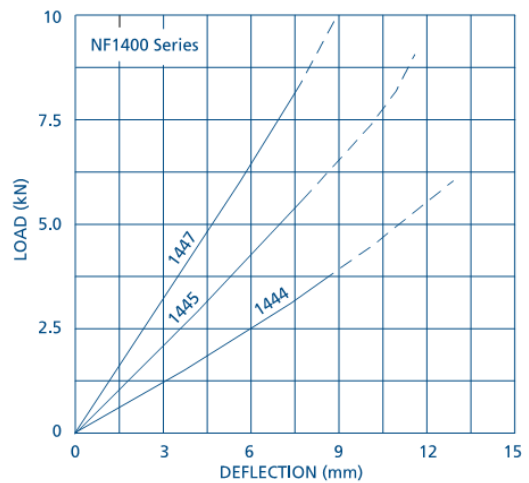

Figure 9: NF1500 Series Load Deflection

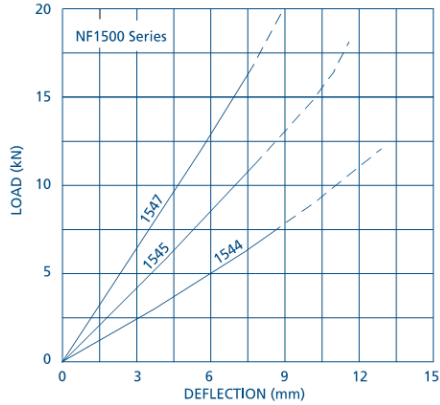

Figure 10: NF2100 Series Load Deflection

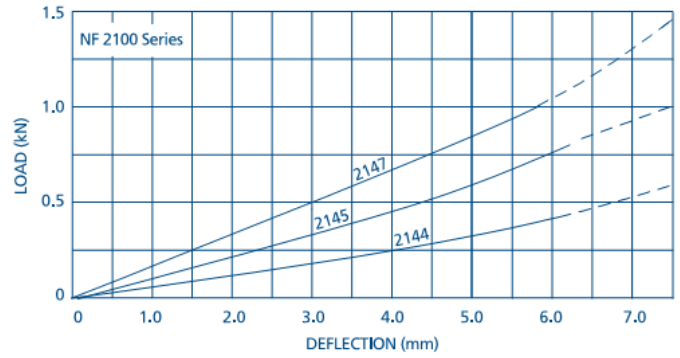

Figure 11: NF2200 Series Load Deflection

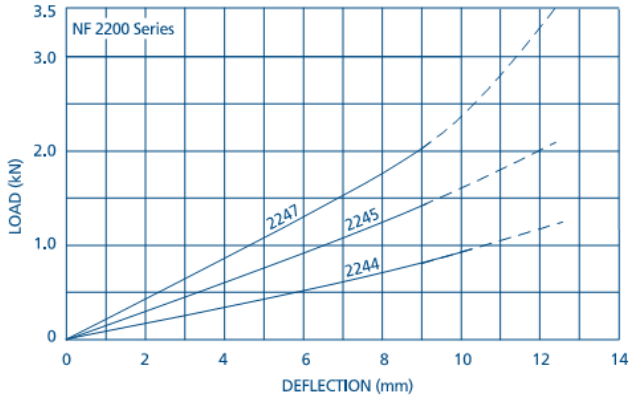

Figure 12: NF2300 Series Load Deflection

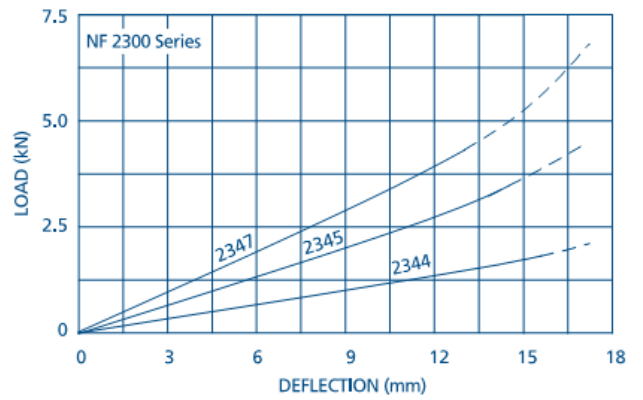

Figure 13: NF2400 Series Load Deflection

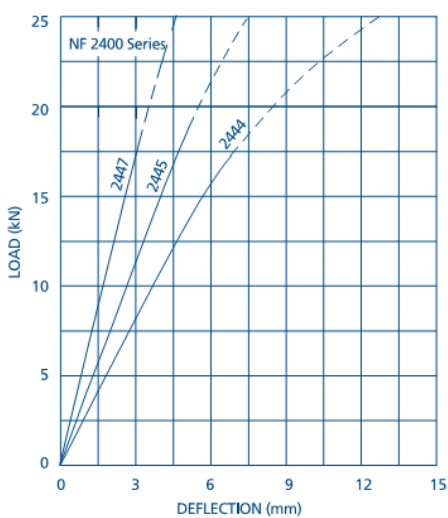
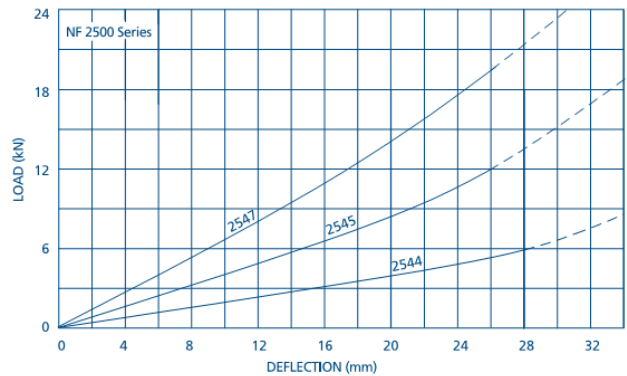

Figure 155: NF2500 Series Load Deflection



Flange Mounts

➤ **Medium Deflection Frustacon – Medium Load**

The Frustacon flange mounting is designed for a recessed fitting into machine frames and engine bearers to reduce installed height.

When incorporated in initial designs, it offers a convenient, economical and compact means of controlling vibration transmission.

Design advantages include security against excessive overload and rebound movement.

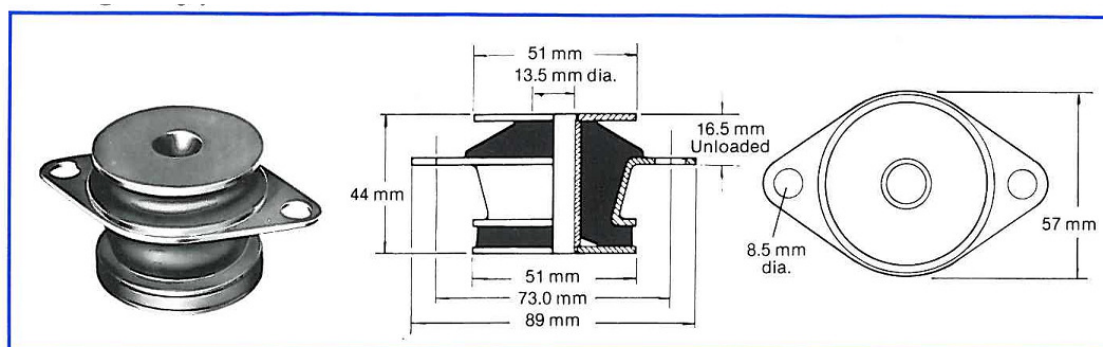

Part #	Normal Load (kg)	Deflection (mm)
FAFL	90	6.4
FBFL	180	6.4

➤ **Tolerances**

Usual acceptable working range of the mounting is 60% to 110% of the normal load. Approximate deflections at loads other than normal can be approximated on a ratio basis. Tolerance on deflection is $\pm 20\%$.



➤ Medium Deflection Frustacon – High Load

The Frustacon flange mounting is designed for recessed fitting into machine frames and engine bearers to reduce installed height.

When incorporated in initial designs, it offers a convenient, economical and compact means of controlling vibration transmission.

Design advantages include security against excessive overload and rebound movement.

This mount has a wide application range including agricultural equipment isolation (tractor cabs), engine mountings generator set mountings, off road vehicles and custom built industrial equipment.

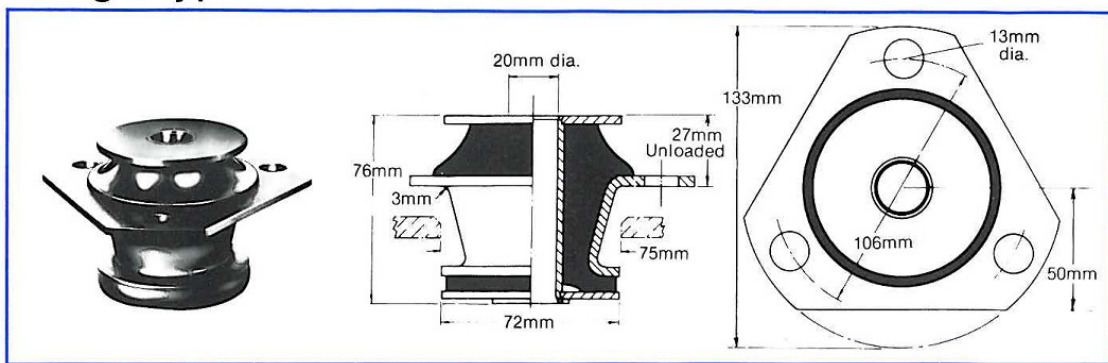

Part #	Normal Load (kg)	Deflection (mm)
FDFL	300	6.0
FEFL	600	6.0

➤ Tolerances

Usual acceptable working range of the mounting is 60% to 110% of the normal load. Approximate deflections at loads other than normal can be approximated on a ratio basis. Tolerance on deflection is $\pm 20\%$.



➤ High Deflection Frustex – Medium Load

Frustex flange mountings are designed for recessed fitting into machine frames and engine bearers to reduce installed height.

Features include security against excessive overload and rebound movement, impact proof lightweight cast aluminium flange, and wide load range.

Where very high flexibility is required, flange mountings may be conveniently combined in series with equivalent flange or pedestal mountings.

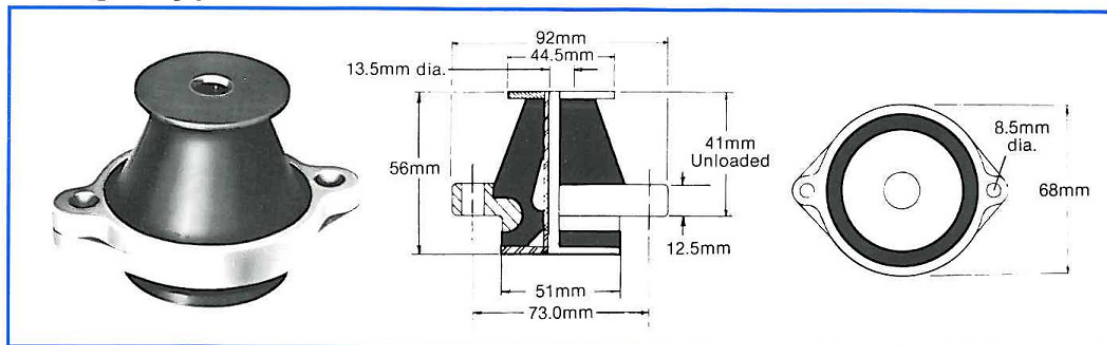

Part #	Normal Load (kg)	Deflection (mm)
FXBFL	180	12.7
FXCFL	270	12.7

➤ Tolerances

Usual acceptable working range of the mounting is 60% to 110% of the normal load. Approximate deflections at loads other than normal can be approximated on a ratio basis. Tolerance on deflection is $\pm 20\%$.



➤ High Deflection Frustex – High Load

Frustex flange mountings are designed for recessed fitting into machine frames and engine bearers to reduce installed height.

Features include movement limiting rebound washers, the same as the pedestal mountings. Flange and inner are aluminium, rebound nut of malleable iron, and flexible element of natural rubber.

These mountings are suitable for use on stationary or some mobile equipment, and may be installed in the inverted position.

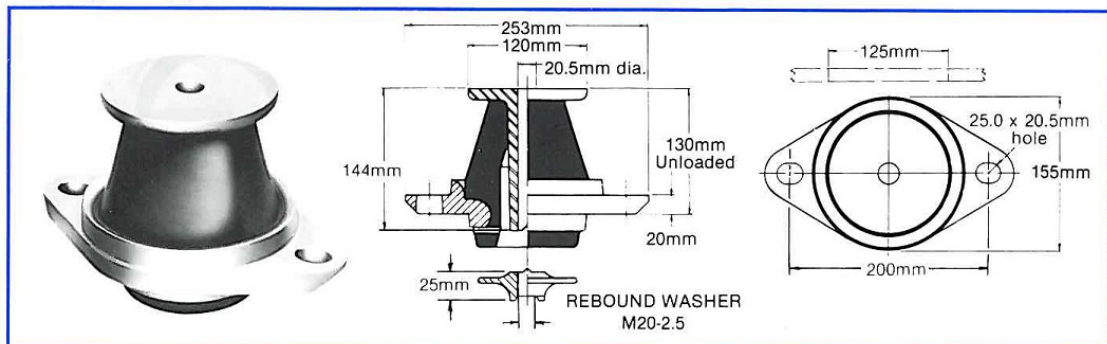

Part #	Normal Load (kg)	Deflection (mm)	Rebound Washer Preload (mm)	
			As Shown	Reversed
FXDFL	800	20	10	5
FXEFL	1300	20	10	5

➤ Tolerances

Usual acceptable working range of the mounting is 60% to 110% of the normal load. Approximate deflections at loads other than normal can be approximated on a ratio basis. Tolerance on deflection is $\pm 20\%$.

➤ Low Deflection – Medium Duty

Flange mountings are designed for recessed fitting into machine frames and engine bearers to reduce installed height. These mountings are robustly constructed and incorporate integral protection against excessive rebound movement. They are particularly suited for applications where lateral movement of installed equipment must be minimised.

This mount has an inbuilt fail safe design that is ideal for critical isolation applications. Examples of these applications are rail, marine and off road. This range of parts is available with a circular flange suitable for pressing in to a housing upon request.

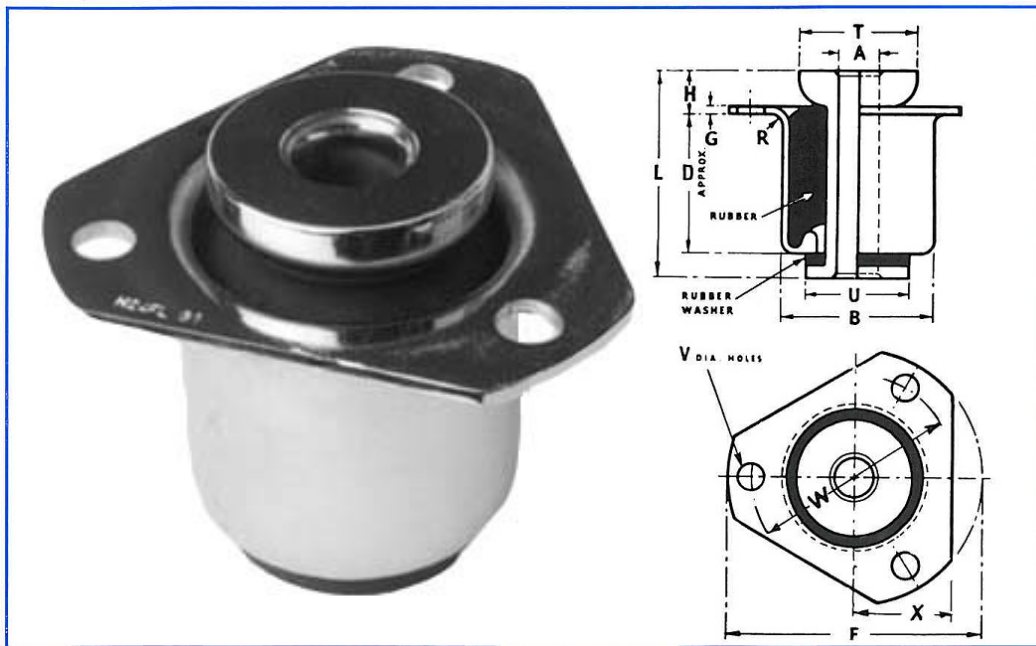

Part #	Dimensions (mm)													Compression	
	A	B	D	F	G	H	L	R	T	U	V	W	X	Normal Load (kg)	Deflection (mm)
J12FL	8.0	22.5	17.5	43	1.2	7.0	30	1.2	16.0	19	4.4	33.3	14.3	7	1.0
J42FL														20	0.9
P47FL	9.8	30.2	27.0	62	1.6	9.5	43	1.6	24.0	22	6.8	47.6	20.6	23	1.8
P15FL														36	1.3
S39FL	12.7	38.1	34.0	70	2.0	10.0	51	1.6	28.5	27	6.8	55.6	25.4	45	3.3
S23FL														80	2.5
R12FL	16.1	47.6	44.0	89	2.3	12.5	64	1.6	39.0	32	8.4	69.9	31.8	110	3.8
R79FL														200	2.0
M46FL	19.3	55.0	51.0	102	2.6	19.0	76	2.4	41.0	38	9.9	82.6	38.1	200	4.6
M81FL														340	3.3
H24FL	22.5	75.0	68.0	133	4.1	20.5	103	3.2	60.5	57	13.1	106.4	50.8	450	5.6
H74FL														680	3.0

➤ Tolerances

Usual acceptable working range of the mounting is 60% to 110% of the normal load. Approximate deflections at loads other than normal can be approximated on a ratio basis. Tolerance on deflection is $\pm 20\%$.

Suspension Isolators

➤ Medium Duty

Originally developed as an isolating support for acoustic ceilings, the Frustex suspension isolator has also been widely adapted for the support of lightweight piping and duct work.

It has a low lateral stiffness and capacity for large conical movement, thus readily permitting movement of the suspended item, such as movement due to the thermal expansion of pipe work.

Its simple installation and low cost, couple with excellent isolation characteristics make it ideal for the support of noise conducting systems in buildings, and for the isolation of suspended equipment in static installation.

All metal parts are of pressed steel, and the flexible element is natural rubber.

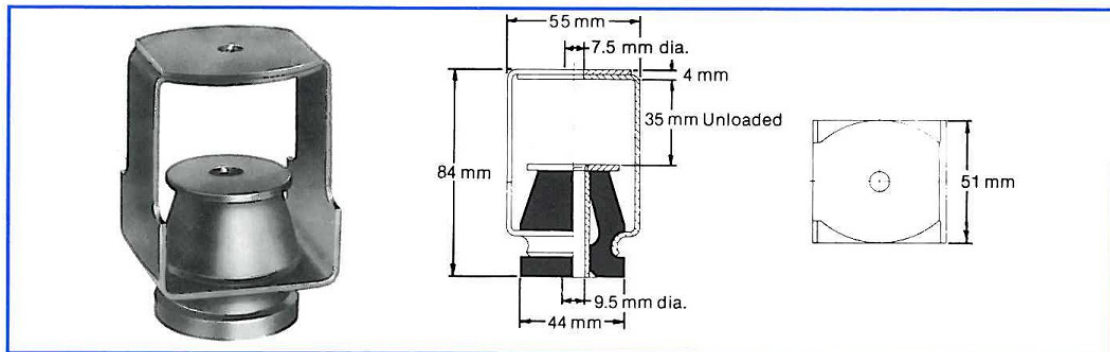

Part #	Normal Load (kg)	Deflection (mm)
FXBHA	45	6.0
FXCHA	90	6.0

➤ Tolerances

Usual acceptable working range of the mounting is 60% to 110% of the normal load. Approximate deflections at loads other than normal can be approximated on a ratio basis. Tolerance on deflection is $\pm 20\%$.



➤ Heavy Duty

Derived directly from Frustex type FXBFL and FXCFL mountings, this isolator provides a convenient form of isolating support for suspended piping and ducts, and for suspended machinery in static installations. It permits considerable lateral movement of the suspended item, thus permitting thermal expansion of supported pipe work.

A strong feature of this mount is the failsafe design. For example: in the event of fire destroying the flexible element, the interlocking metal parts ensure that full load support is retained.

This mount is ideally suited to the building and construction industry.

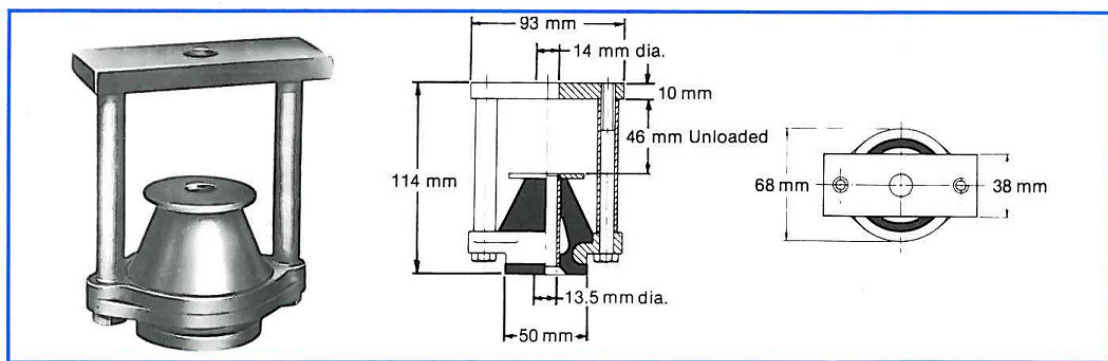

Part #	Normal Load (kg)	Deflection (mm)
FXBH	180	12.7
FXCH	270	12.7

➤ Tolerances

Usual acceptable working range of the mounting is 60% to 110% of the normal load. Approximate deflections at loads other than normal can be approximated on a ratio basis. Tolerance on deflection is $\pm 20\%$.



Side Attachment Mounts

The Frustacon side mounting is designed to permit convenient installation of equipment with limited base surfaces and to permit low installed height.

Design features include excellent isolation characteristics, security against excessive overload and rebound movement, and robust cast aluminium body.

This highly versatile mount can be used in a wide variety of applications such as large instrument panels, office equipment, light workshop machinery, portable machinery and general industrial applications.

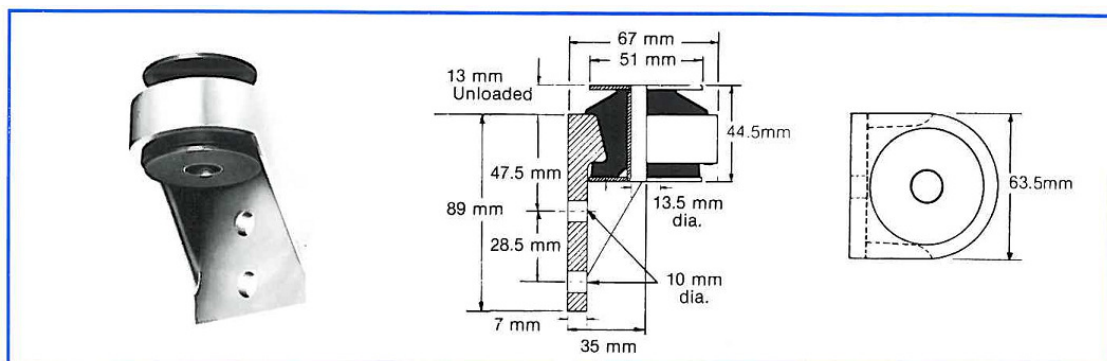

Part #	Normal Load (kg)	Deflection (mm)
FAS	90	6.4
FBS	180	6.4

➤ Tolerances

Usual acceptable working range of the mounting is 60% to 110% of the normal load. Approximate deflections at loads other than normal can be approximated on a ratio basis. Tolerance on deflection is $\pm 20\%$.



Machine Levelmounts

The Silentbloc Levelmount is an extremely versatile vibration isolation mount that can be used in a wide range of industrial applications.

Designed to absorb vibration and reduce noise, Levelmounts also allow fast, easy installation or relocation of machinery.

No special floor preparation is required, and there is no expense for bolts, anchor plates, masonry drilling and re-cementing.

Machine placement is not restricted by the presence of conduit, pipes, girders or reinforcement rods when you use Levelmounts. They can be moved and re-aligned easily to give the greatest layout efficiency. Whether a machine's operating motion is rotary, reciprocating or impact, it can be satisfactorily installed on levelmounts without any tendency to walk. This means they can be simply and effectively installed on lathes, milling machines, grinders, metal working shears and presses, shapers and planers etc.



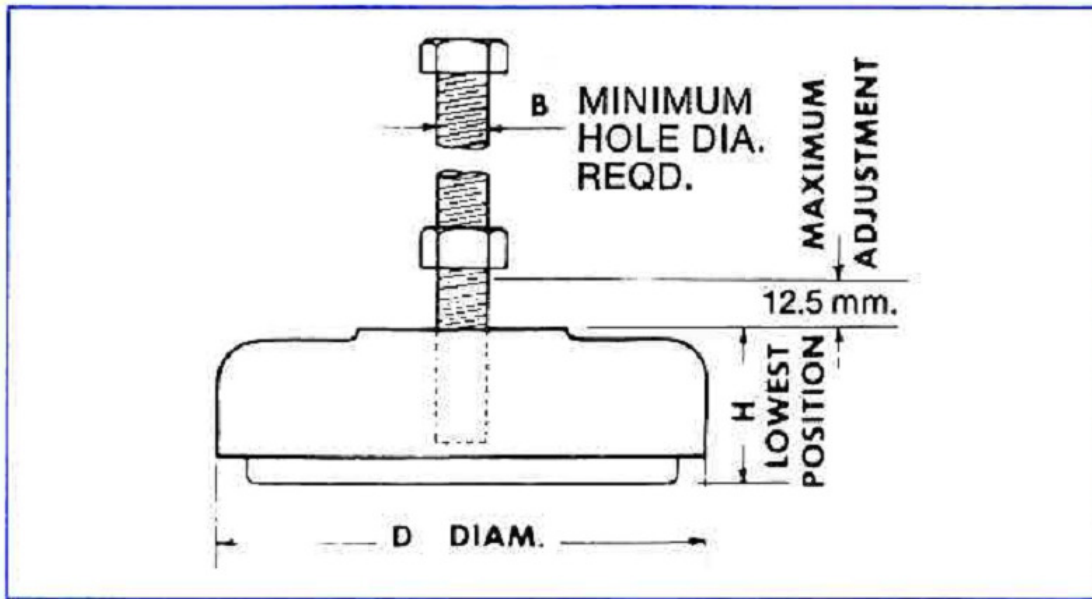

Figure 6: SLM500 – SLM1000

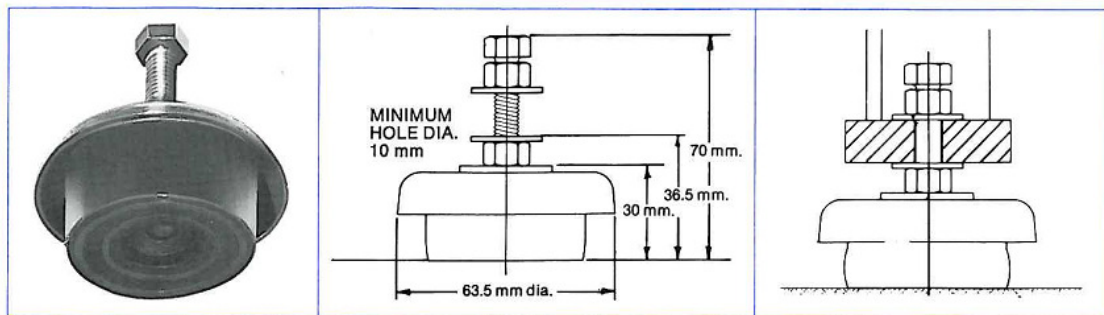

Figure 7: SLM100

Part #	Maximum Rated Loads (kg)		Dimensions (mm)		
	General Machinery	Impact Machinery	D	H	B
SLM100	55	40	Refer Diagram		
SLM500	500	375	102	43	13
SLM1000	1000	750	149	48	16
SLM1500	1500	1000	178	52	20
SLM3000	3000	2000	203	56	20
SLM5000	5000	3750	260	69	24
SLM10000	10000	7500	317	70	30

Movable Mounts

➤ Medium Deflection Frustacon – Medium Load

This Frustacon movable mounting is designed for applications where positive base fixing is undesirable or where frequent relocation of mounted equipment is necessary. It is typically employed beneath office machinery where fixing through carpet or tile floor coverings is undesirable; for temporary installation of emergency plant and beneath portable machinery and instruments. This mounting has excellent isolation characteristics, and a protective steel cover, and is designed to prevent the “walking” of mounted equipment on any reasonable surface.

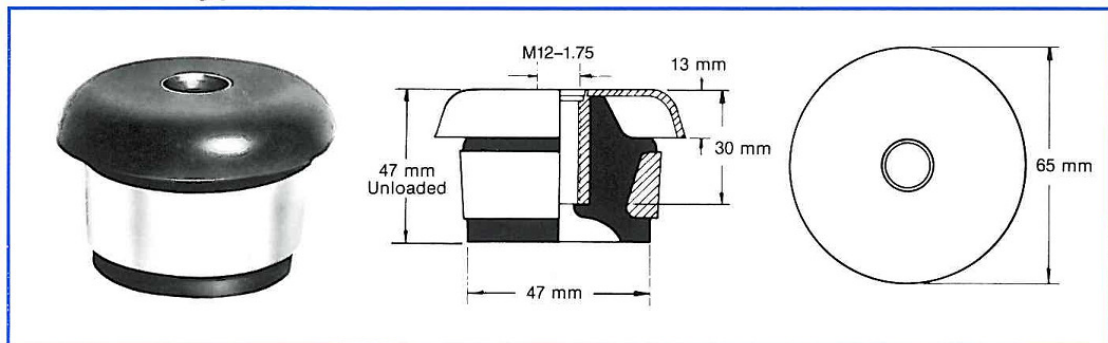

Part #	Normal Load (kg)	Deflection (mm)
FAM	90	6.4
FBM	180	6.4

➤ Tolerances

Usual acceptable working range of the mounting is 60% to 110% of the normal load. Approximate deflections at loads other than normal can be approximated on a ratio basis. Tolerance on deflection is $\pm 20\%$.



Industrial Bearings

➤ Standard Industrial Range

Flexible bearings are designed to accommodate radial, axial, conical or torsional loading or any combination of these four forces. They isolate noise, vibration and shock, accommodate misalignment and eliminate the need for lubrication.

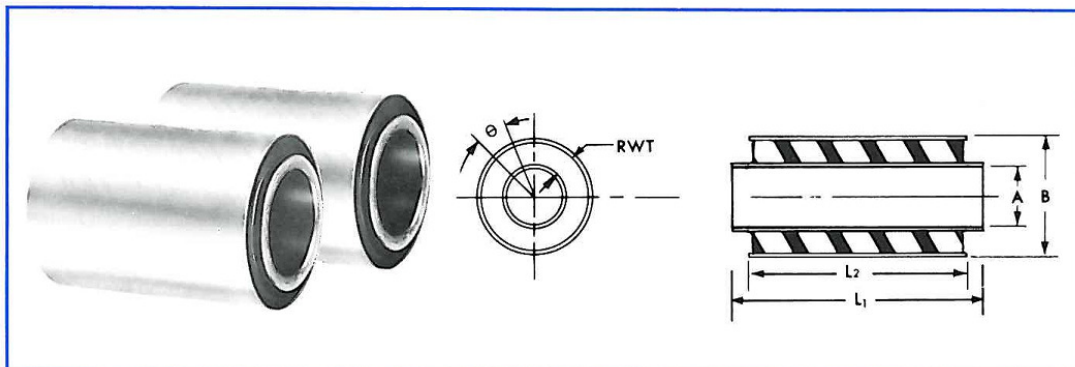

* Not a stock item – long lead times may apply

Part #	Dimensions (mm)				Rubber Wall Thickness	Radial Load (kg)	Torsional Load (±degrees)
	A	B	L1	L2			
E0981*	4.8	11.1	7.9	6.4		11	15
E20021*	6.1	14.3	19.1	17.5		64	15
E10011*	6.4	14.3	12.7	11.1		28	15
E2004*	6.4	14.3	19.1	17.5		64	15
E2000*	6.4	14.3	20.6	10.1		70	15
E1002*	6.4	17.5	19.1	17.5		43	15
E1000*	6.4	17.5	22.2	19.1		47	15
E10158*	6.4	19.1	22.2	19.1		47	15
E1010*	6.4	19.1	25.4	22.2		55	15
E2005*	7.9	14.3	20.6	19.1		79	15
E2003*	7.9	14.3	23	21.4		89	15
E2010*	7.9	15.9	24.6	22.2		97	15
E2020*	7.9	17.5	27.8	25.4		120	15
E1020	7.9	20.6	28.6	25.4	3.3	64	26
E1032*	7.9	22.2	27.8	25.4		80	15
E1030	7.9	22.2	31.8	28.6	4.1	84	28
E20321*	9.5	19.1	22.2	20.6		111	15
E2030*	9.5	19.1	31	28.6		154	15
E2042*	9.5	20.6	22.2	19.1		103	15
E20473*	9.5	20.6	27	23.8		129	15
E2040*	9.5	20.6	34.9	31.8		171	15
E20419	9.5	20.6	42.9	38.1	2.5	205	26
E1067*	9.5	23.8	21	19.1		68	15
E1072*	9.5	23.8	27	23.8		81	15
E20612*	9.5	23.8	28.6	22.2		143	15
E1065*	9.5	23.8	30.2	25.4		92	15
E10817*	9.5	25.4	28.6	25.4		97	15
E1085*	9.5	25.4	36.5	31.8		121	15
E1080	9.5	25.4	49.2	44.5	4.1	155	26
E1090*	9.5	25.4	52.4	47.6		183	15
E20333*	9.7	19.1	28.6	27.9		150	15
E20474*	10.3	20.7	27	23.8		144	15
E20522*	11.1	22.2	22.2	19.1		109	15
E20553*	11.1	22.2	22.2	19.1		122	15
E2058*	11.1	22.2	31.8	28.9		183	15
E2050*	11.1	22.2	38.1	34.9		223	15
E2053*	11.1	22.2	41.3	38.1		244	15
E2057	11.1	22.2	44.5	38.1	2.5	203	20

Part #	Dimensions (mm)				Rubber Wall Thickness	Radial Load (kg)	Torsional Load (±degrees)
	A	B	L1	L2			
E2051*	11.1	22.2	47.6	44.5		285	15
E20632*	11.1	23.8	22.2	19.1		122	15
E2062*	11.1	23.8	28.6	25.4		162	15
E20610*	11.1	23.8	38.1	34.9		223	15
E2060*	11.1	23.8	41.3	38.1		244	15
E20728*	11.1	25.4	35	28.6		153	15
E2077*	11.1	25.4	36.5	28.6		184	15
E20719*	11.1	25.4	41.3	38.1		244	15
E2075*	11.1	25.4	47.6	44.5		285	15
E2073*	11.1	25.4	54	50.8		326	15
E1102*	11.1	27	38.1	34.9		149	15
E1104*	11.1	27	38.1	34.9		149	15
E21083*	11.1	30.2	44.5	38.1		323	15
E20550*	11.2	22.6	22.3	19.1		122	15
E20638*	12.1	23.8	25.4	25.4		164	15
E2088*	12.1	27	34.9	31.8		241	15
E20825*	12.1	27	38.1	34.9		265	15
E2086*	12.1	27	41.3	38.1		289	15
E2080*	12.1	27	47.6	44.5		338	15
E20839*	12.1	27	60.3	50.8		386	15
E20822	12.7	27	50.8	44.5	2.8	337	18
E2099*	12.7	28.6	28.6	25.4		193	15
E2095*	12.7	28.6	31.8	28.6		217	15
E11124*	12.7	28.6	33.3	31.8		143	15
E1115*	12.7	28.6	33.3	28.6		129	15
E2090	12.7	28.6	50.8	47.6	3.6	361	21
E21043*	12.7	30.2	79.4	73		592	15
E1135*	12.7	31.8	46	44.5		224	15
E1141*	12.7	33.3	28.6	25.4		129	15
E21347*	12.7	33.3	38.1	31.8		319	15
E21359*	12.7	33.3	38.1	31.8		319	15
E1158	12.7	34.9	44.5	41.3	6.9	191	29
M2270*	14	48	44	40		439	14
E20884*	14.1	27.1	28	25.1		192	15
E2108*	14.29	30.16	60.33	50.8		394	15
E21076*	14.29	30.16	92.08	85.73		708	15
E2113*	14.29	31.75	34.93	31.75		262	15
E2111*	14.29	31.75	53.98	50.79		419	15
E2115*	14.29	31.75	57.15	50.8		419	15
E2120*	14.29	31.75	61.91	57.15		472	15
E1164*	14.3	28.6	40.5	36.5		196	15
E21032*	14.3	30.2	50.8	44.5		367	15
E11389*	14.4	31.8	38.1	28.6		148	15
E20947*	15.88	28.58	44.45	41.28		334	15
E21260*	15.88	31.75	34.93	31.75		284	15
E2134*	15.88	31.75	47.63	44.45		397	15
E2122*	15.88	31.75	61.91	57.15		471	15
E2135*	15.88	33.34	44.45	38.1		341	15
E2133*	15.88	33.34	53.98	50.8		454	15
E21316*	15.88	33.34	57.15	50.8		454	15
E2130*	15.88	33.34	65.09	60.33		539	15
E2141*	15.88	34.93	38.1	34.93		330	15
E2145*	15.88	34.93	50.8	44.45		420	15
E2146*	15.88	34.93	57.15	50.8		480	15
E2140*	15.88	34.93	68.26	63.5		600	15
E21323	15.9	31.8	28.6	25.4	3.3	212	17
E2133*	15.9	33.3	54	50.8	4.1	429	20
E2149	15.9	34.9	41.3	34.9	5.3	263	23
E1171*	15.9	38.1	28.6	25.4		151	15
E1176*	15.9	38.1	41.3	38.1		227	15
E1170	15.9	38.1	79.4	73	6.4	413	26
E21082*	15.94	30.16	34.93	31.75		285	15
M21411*	16	32	26	20		186	14
M1142*	16	38	72	60		371	14
M1165*	16	41.34	104	79.23		446	14

Part #	Dimensions (mm)				Rubber Wall Thickness	Radial Load (kg)	Torsional Load (±degrees)
	A	B	L1	L2			
M11711*	16	44	70	65		402	
E21355*	19.05	31.83	39.5	31.75		310	15
E2171*	19.05	38.1	41.28	38.1		411	15
E2174*	19.05	38.1	53.98	50.8		548	15
E2173*	19.05	38.1	61.94	57.15		616	15
E21854*	19.05	38.1	68.26	63.5		685	15
E2170*	19.05	38.1	77.79	73.03		788	15
E2203*	19.05	38.1	85.73	76.2		821	15
E1232*	19.1	42.9	54	50.8		357	15
E12391*	19.1	42.9	54	47.6		343	15
E1230*	19.1	42.9	90.1	85.7		616	15
E2182	20	38.1	68.3	63.5	4.3	685	18
E1231	20	42.9	41.3	38.1	6.6	279	24
E2239	22.2	42.9	63.5	57.2	5.1	692	26
E12568*	22.2	46	63.5	57.2		462	15
E1271*	22.2	49.2	66.7	57.2		462	15
E1270*	22.2	49.2	106.4	98.4		796	15
E22367*	22.23	42.86	34.93	31.75		385	15
E2244*	22.23	42.86	47.63	44.45		539	15
E2245*	22.23	42.86	53.98	50.8		616	15
E22372*	22.23	42.86	60	57.15		693	15
E2236*	22.23	42.86	79.38	76.2		924	15
E22787*	25.4	44.45	69.85	63.5		855	15
E22790*	25.4	44.45	69.85	63.5		855	15
E2271	25.4	46	68.3	63.5	5.1	854	18
E2284*	25.4	46.04	47.63	44.45		599	15
E22725*	25.4	46.04	50.8	47.63		644	15
E2270*	25.4	46.04	104.78	98.43		1326	15
E22716*	25.4	47.63	33.34	31.75		428	15
E22718*	25.4	47.63	44.45	38.1		513	15
E22768*	25.4	47.63	47.63	46.04		620	15
E22793*	25.4	47.63	66.68	57.15		769	15
E22778*	25.4	47.63	103.19	95.25		1283	15
E1331*	25.4	50.8	57.2	50.8		456	15
E13244*	25.4	50.8	88.9	85.7		848	15
E22782*	25.4	52.5	68.26	63.5		855	15
E13232*	25.4	54	57.2	50.8		456	15
E13240*	25.4	54	73	63.5		570	15
E1323*	25.4	54	88.9	76.2		684	15
M22510*	28	48	55	50		717	14
E23749*	28.64	54.67	123.8	114.3		1773	15
E1362*	28.7	57.2	88.9	85.7		848	15
E2360*	30.24	50.88	130.18	120.66		1871	15
E23716*	31.75	53.98	57.15	53.98		908	15
E2384*	31.75	53.98	68.26	63.5		1068	15
E2376*	31.75	53.98	85.73	79.38		1336	15
E2371*	31.75	53.98	95.25	90.49		1523	15
E2370*	31.75	53.98	133.35	123.83		2084	15
E23823*	31.75	53.98	165.1	63.5		1068	15
E23719*	31.75	57.15	38.1	37.3		628	15
E23711	31.8	54	111	101.6	5.1	1715	15
E1438*	31.8	63.5	57.2	50.8		570	15
E14325*	31.8	63.5	63.5	104		1166	15
E1441*	31.8	69.9	127	114.3	12.2	999	29
E24374*	31.99	65.07	79.43	69.85		1404	15
E14360*	32	63.5	57.2	50.8		573	15
E2426	34.9	58.7	74.6	69.9	5.6	1270	16
E2425*	34.93	58.74	111.13	101.6		1846	15
M2257*	35	48	47	42		678	14
E24362*	38.1	65.09	66.68	57.15		1155	15
E2434*	38.1	65.09	76.2	73.03		1476	15
E24363*	38.1	65.09	76.2	66.68		1347	15
E24333*	38.1	65.09	95.25	88.9		1796	15
E2432*	38.1	65.09	133.35	127		2566	15
E2440*	38.1	65.09	155.58	146.05		2951	15

Part #	Dimensions (mm)				Rubber Wall Thickness	Radial Load (kg)	Torsional Load (±degrees)
	A	B	L1	L2			
E2437	38.1	65.1	68.3	63.5	6.6	1152	16
E2458*	38.1	69.85	95.25	88.9		1796	15
E14623*	38.1	69.9	67.4	66		827	15
E1466*	38.1	69.9	69.9	63.5		797	15
E14625*	38.1	69.9	74.9	73.7		921	15
E24313*	38.2	65.09	76.2	69.85		1414	15
E24360*	39.71	63.5	82.55	76.14		1531	15
M23617*	42	78	66	60		1494	14
M23618*	42	80.1	85	79		2001	14
M23619	42	78	140	130		2000	15
E2473*	44.45	76.2	50.8	47.63		1151	15
E24719*	44.45	76.2	63.5	60.33		1406	15
E24722*	44.45	76.2	95.25	88.9		2149	15
E2477*	44.45	76.2	139.7	127		3143	15
M2713FG*	50	165	140	130		7135	14
E2526	50.8	85.7	82.6	76.2	8.4	2046	16
E25280*	50.8	85.73	101.6	95.25		2557	15
E2525*	50.8	85.73	104.78	98.43		2643	15
E2529*	50.8	85.73	139.7	127		3410	15
E2522*	50.8	85.73	165.1	152.4		4092	15
E2629*	50.8	98.43	161.93	152.4		4092	15
E25310*	53.98	88.9	92.08	88.9		2430	15
E2603*	57.15	92.08	82.55	76.2		2250	15
E26037*	57.15	92.08	111.13	101.6		3000	15
E2618*	57.15	95.25	120.65	114.3		3376	15
E1611*	57.2	104.8	146.1	130.2		2562	15
E2614*	60.39	92.08	177.8	95.25		2812	15
E2632*	63.5	104.78	107.95	101.6		3430	15
E26368*	63.5	104.78	127	120.65		3430	15
E26317	63.5	104.8	152.4	142.5	9.9	4827	15
E2711*	73.03	107.95	120.65	127		4457	15
E28071*	76.2	107.95	135.1	120		4592	15
E28058*	76.2	120.65	158.75	146.05		5788	15
E2808*	76.2	120.65	174.63	165.1		6546	15
E28055*	76.2	120.65	190.5	152.4		6040	15
E2800*	76.2	120.65	269.88	254		10066	15
E16837*	76.2	139.7	149.2	139.7		3743	15
M2627*	80	140	182	170		8038	14
E2816*	82.61	127	140	133		5510	15
E28117*	88.89	121.9	38	37		1531	15
E28434*	88.9	138.7	149	143		6531	15
E2847*	88.9	139.7	140	127		5816	15
E28466*	88.9	139.7	217	165		7551	15
E2840*	88.9	139.7	292	279		12755	15
M2712FG*	100	165	140	130		7135	14
M1781*	100	172.1	120	110		3531	14
E2851*	109.46	143.04	108	102		5204	15
M2722*	120	170	120	110		6316	14
E2933*	120.65	187.33	203	191		11531	15
E2932*	125.04	188.32	191	191		11531	15
M2741*	138	192	130	124		7956	14

* Not a stock item – long lead times may apply



➤ High Axial Load Range

The EX3000 & EX4000 series of flexible bearings have a high axial load carrying capability. The load shown in the table below is the normal working radial load.

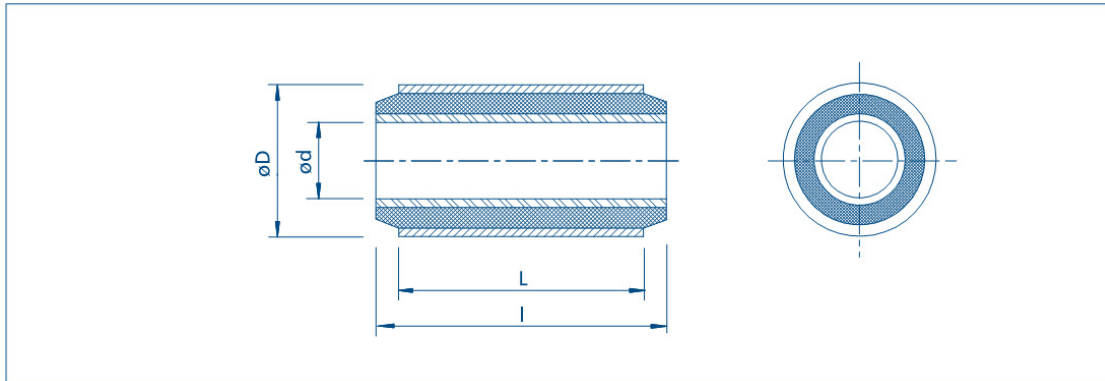

* Not a stock item – long lead times may apply

Part #	Dimensions (mm)				Radial Load (kg)
	d	D	l	L	
EX31135*	12.7	28.6	38.1	31.8	224
EX31136*	11.2	28.6	38.1	31.8	230
EX31525*	11.1	35.0	38.1	31.8	281
EX31532*	11.2	34.9	54.0	44.5	388
EX31533*	11.1	35.0	38.1	31.8	281
EX317100*	9.8	38.1	46.7	35.6	357
EX40460*	9.5	20.6	46.0	38.1	214
EX40737*	11.1	25.4	42.9	38.1	255
EX40742*	11.1	25.4	54.0	50.8	327
EX40758*	12.7	25.7	57.2	50.8	337
EX40951*	14.3	28.6	60.3	50.8	357
EX41032*	14.3	30.2	50.8	44.5	337
EX41123*	12.9	31.8	58.7	50.8	408
EX4130*	15.9	33.3	65.1	60.3	510
EX41316*	15.9	33.3	57.2	50.8	418

* Not a stock item – long lead times may apply

➤ Bonded Range

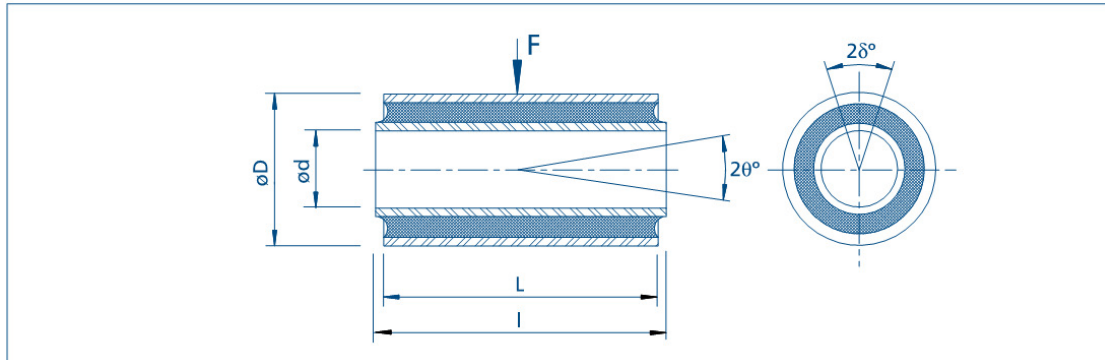

* Not a stock item – long lead times may apply

Part #	Dimensions (mm)				Radial Load (kg)	Radial Stiffness (kg/mm)
	d	D	l	L		
EB10122*	6.4	19.1	15.9	12.7	36	51
EB11796*	12.7	38.1	50.8	44.5	383	423
EB1218*	12.7	41.2	64.3	50.8	663	918
EB13258*	12.7	50.8	50.8	31.8	153	56
EB2857*	16.0	50.0	76.0	66.0	918	1582
EB2357*	25.0	51.0	95.0	90.0	3469	3673
EB14356*	25.5	65.5	26.2	24.9	153	51
EB1473*	31.8	74.9	38.0	24.6	173	51
EB3000*	38.1	69.9	62.2	61.0	765	1071
EB24777*	44.5	76.0	114.3	114.3	7653	143
EB24772*	44.5	76.2	120.5	114.0	102	153
EB24616*	44.5	76.7	133.4	125.5	5408	7245
EB24617*	44.5	78.5	133.4	129.5	8163	12245
EB1618*	44.5	101.6	88.9	82.6	1403	765
EB2854*	45.0	76.1	79.8	77.7	3061	5459
EB1691*	74.7	152.5	105.0	90.0	2423	1224
EB2852*	88.9	142.9	108.0	101.6	4388	2449
EB2855*	160.1	204.2	173.3	166.8	34694	33980

* Not a stock item – long lead times may apply

➤ Loading Types & Ratings

➤ Radial Loading

Nominal static stress limit for radial loading is based on the torsional angle not exceeding 50% of rated angle. Occasional shock loads up to 5 times rated load are acceptable.

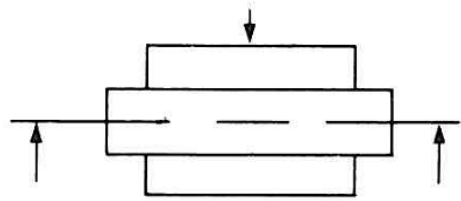

➤ Conical Loading

Maximum conical angle is that at which the rubber wall thickness is reduced by 30% at one end of the outer sleeve.

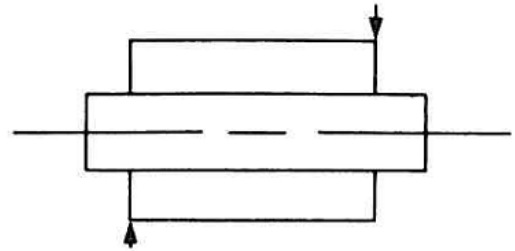

➤ Axial Loading

Axial loads should not exceed 10% of rated radial load. Axial deflection should not exceed 50% of the rubber wall thickness.

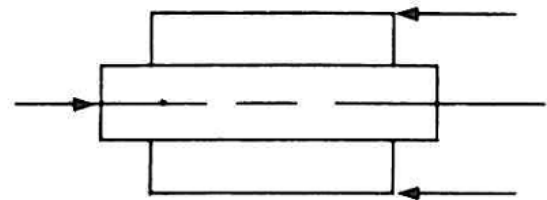

➤ Torsional Loading

Rated torsion angles are for oscillation frequencies below 100 cycles per minute, and radial loads below 50% of rated load. When oscillation frequency exceeds 100 cycles per minute, allowable torsional angle must be reduced in inverse proportion to frequency. For radial loads above 50% of rated loads refer combination loading notes.

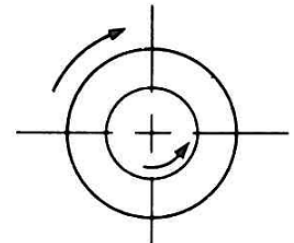

➤ Combination Loading

Capacities for any type of load reduce when combinations of loading occur. Inter-relationships of loadings cannot be readily represented by formulae, and applications involving appreciable combination loadings should be referred to Silentbloc for bearing selection.

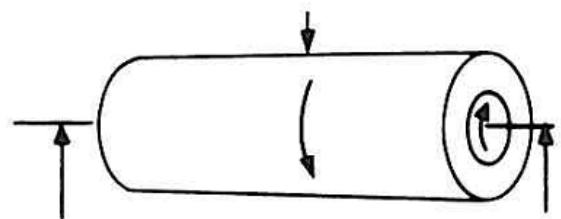

Subject to limits of oscillation frequency noted above, simple combinations of radial and torsional loads bear the following maximum relationships: 100% rated load or angle to 50% rated angle or load, 75% rated load to 75% rated angle.

➤ **Installation Notes**

1. Silentbloc flexible bearings should be installed such that angular movement will be equalised about the bearing “free” position.
2. Usual fixing for the outer sleeve is by interference fit only. Suggested fits are given in the housing fits section. When pressing a bearing into position, care must be taken to ensure that pressure is applied only to the outer sleeve, and not to the inner sleeve or rubber.
3. Usual fixing for the inner sleeve is by axial pressure on the ends of the sleeve, such as obtained from a securely tightened nut and bolt passing through the sleeve; grip on the sleeve end can be improved by using internal toothed spring washers.

➤ **Bearing Tolerances**

It is advisable when ordering bushes to first obtain the actual manufacturing tolerances of the part, however the tables below give a general indication of the tolerances.

Nominal Diameter d (mm)	Tolerances (mm)	
	d	l
6 to 16	+0.13 -0.00	+0.08 -0.08
Over 16 to 25	+0.13 -0.00	+0.10 -0.10
Over 25 to 38	+0.13 -0.00	+0.13 -0.13
Over 38 to 51	+0.13 -0.00	+0.15 -0.13
Over 51 to 90	+0.13 -0.00	+0.18 -0.13

Nominal Diameter D (mm)	Tolerances (mm)	
	D	L
Up to 22	+0.05 -0.00	+0.08 -0.13
Over 22 to 44	+0.08 -0.00	+0.10 -0.13
Over 44 to 70	+0.08 -0.00	+0.13 -0.13
Over 70 to 102	+0.08 -0.00	+0.15 -0.13
Over 102 to 140	+0.08 -0.03	+0.15 -0.15

➤ Housing Fits

The tables below give suggested housing interference fits for the measured size of the bearing.

Nominal Diameter D	Housing Fit (mm)
Up to 17mm	-0.03 -0.05
Over 17mm to 32mm	-0.04 -0.06
Over 32mm to 51mm	-0.05 -0.09
Over 51mm to 81mm	-0.06 -0.11
Over 81mm to 127mm	-0.08 -0.13
Over 127mm to 178mm	-0.10 -0.17

Table 1: Rigid housing fits

Nominal Diameter D	Housing Fit (mm)
Up to 22mm	-0.25 -0.51
Over 22mm to 30mm	-0.38 -0.64
Over 30mm to 37mm	-0.64 -0.89
Over 37mm to 43mm	-0.76 -1.0
Over 43mm to 56mm	-0.89 -1.1
Over 56mm to 70mm	-1.0 -1.4

Table 2: Rolled spring eye housings

When using the above limits it must be borne in mind that the outer sleeve of the Silentbloc bearing is tubular, and the actual interference fit is less than would be obtained with a solid of corresponding dimensions. The dimensions for holes have been designed to provide suitable interference fits for torsional movement, but smaller interferences should be used where the housing or eye is of light construction, or where the Silentbloc bearing is not called upon to take such movement.

Flexible Ball Joints

➤ Parallel Bore

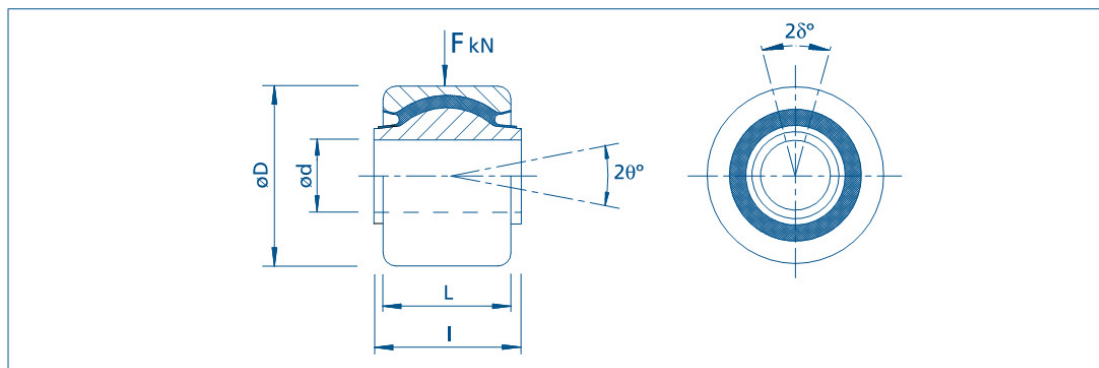

* Not a stock item – long lead times may apply

Part #	Dimensions (mm)				Radial		Torsional		Conical	
	D	d	L	l	Normal Load (kN)	Stiffness (MN/m)	Normal Displacement (±°)	Stiffness (kNm/rad)	Normal Displacement (±°)	Stiffness (kNm/rad)
BJH024*	66	25	48	54	35	70	8	1.0	7	1.3
BJ024*	66	25	48	54	35	50	8	0.7	6	0.5
BJM3332*	66	25	48	54	35	70	8	1.3	7	1.4
BJH055*	67	25	48	54	50	85	8	1.5	7	1.7
BJM3371*	75	40	43	43	85	145	4	2.4	2	2.4
BJM3421QF*	84	40	66	72	40	65	8	2.3	6	4.8
BJM3421QH*	84	40	66	72	60	100	8	3.4	6	7.0
BJM3451*	90	30	65	83	55	75	8	2.0	6	2.5
BJM3456*	90	45	65	70	50	70	8	2.0	6	2.5
BJM3469Q1*	90	45	54	62	65	88	8	2.7	6	2.1
BJM3469Q2*	90	45	54	62	85	118	8	3.4	6	2.8
BJH069Q1*	90	45	54	62	65	88	8	2.7	6	2.1
BJH069Q2*	90	45	54	62	85	118	8	3.4	6	2.8
BJM3453*	90	43	65	76	80	110	8	3.0	6	3.7
BJ012*	90	29	70	76	75	70	8	3.0	9	2.0
BJ029-B*	90	28	70	76	65	90	8	2.8	6	2.8
BJM3454*	90	28	65	76	85	100	8	2.8	6	3.5
BJ014*	105	38	76	82	80	85	8	4.0	7	4.0
BJH014*	105	38	76	82	120	130	8	6.0	7	9.0
BJ031*	127	45	101	105	120	130	10	9.0	7	11.3
BJ032*	127	50	101	105	120	130	10	9.0	7	11.3
BJH042*	127	55	102	115	120	130	10	9.0	7	11.0

* Not a stock item – long lead times may apply

➤ Tapered Bore

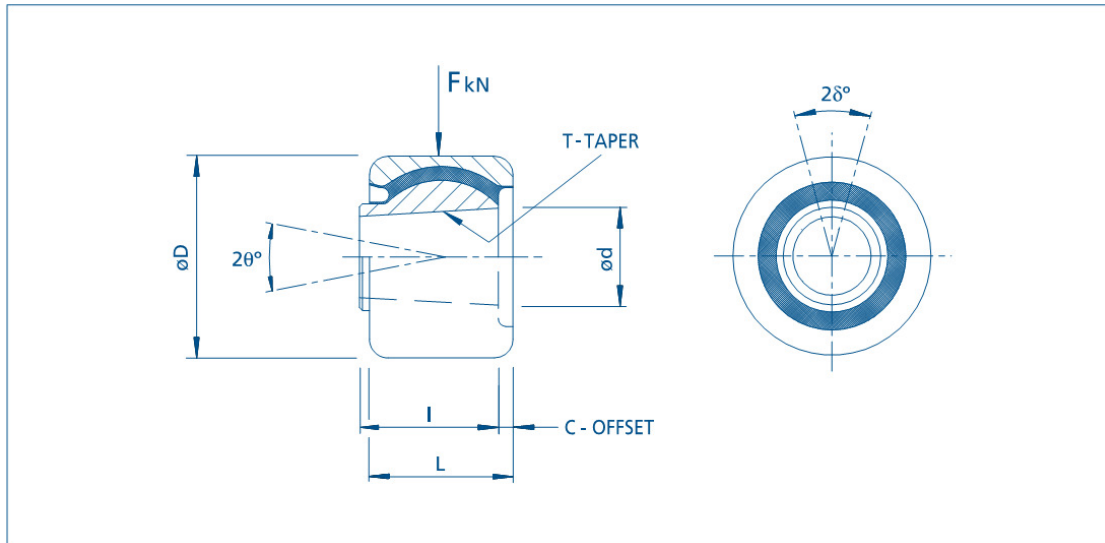

* Not a stock item – long lead times may apply

Part #	Dimensions (mm)						Radial		Torsional		Conical	
	D	d	T°	C	L	l	Normal Load (kN)	Stiffness (MN/m)	Normal Displacement (±°)	Stiffness (kNm/rad)	Normal Displacement (±°)	Stiffness (kNm/rad)
BJM3455*	90	42.5	0.2	0	54	60	16	19	7	1.1	5	0.7
BJ013*	90	41	0.2	8	70	65	60	60	8	2.2	9	2.0
BJ030-B*	90	41	0.2	8	70	65	65	90	8	1.9	6	1.7
BJ021*	105	47.5	0.2	9.5	76	70	50	52	8	3.4	10	2.6

* Not a stock item – long lead times may apply

➤ Solid Extended Pin Parallel Face

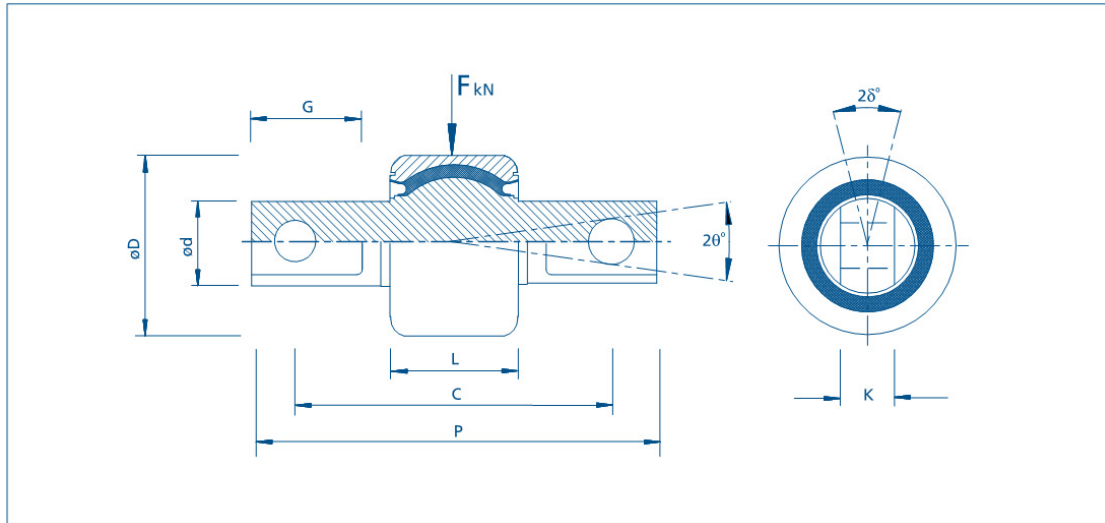

* Not a stock item – long lead times may apply

Part #	Dimensions (mm)							Radial		Torsional		Conical	
	D	L	d	C	G	K	P	Normal Load (kN)	Stiffness (MN/m)	Normal Displacement (±°)	Stiffness (kNm/rad)	Normal Displacement (±°)	Stiffness (kNm/rad)
BJM3340*	67	48	35	90	35	20	120	35	70	6	1.3	8	1.7
BJM3341*	67	48	35	96	38	20	126	25	50	6	1.0	8	1.2
BJM3333QD*	67	48	35	90	35	20	120	22	45	6	0.9	8	1.1
BMJ3333QG*	67	48	35	90	35	20	120	35	70	6	1.3	8	1.7
BJM3334*	67	48	35	90	35	20	120	35	70	6	1.3	8	1.7
BJH050*	67	48	35	118	41	20	150	50	70	8	1.0	7	1.3
BJH054*	67	48	35	118	41	20	150	50	85	8	1.5	7	1.7
BJH059*	67	48	35	96	38	20	126	50	85	8	1.5	7	1.7
BJ015*	90	70	36	N/A	35	25	170	75	70	8	3.0	9	2.0
BJH044*	90	70	48	130	50	30	170	65	90	10	2.8	8	2.8
BJH047*	90	70	48	130	50	25	170	20	30	10	1.0	8	1.0
BJH053*	90	70	48	130	51	27	172	65	90	10	2.5	8	2.3
BJH015*	90	70	48	140	57	30	190	65	90	10	2.8	8	2.8

* Not a stock item – long lead times may apply

➤ **Solid Extended Pin Tapered Face**

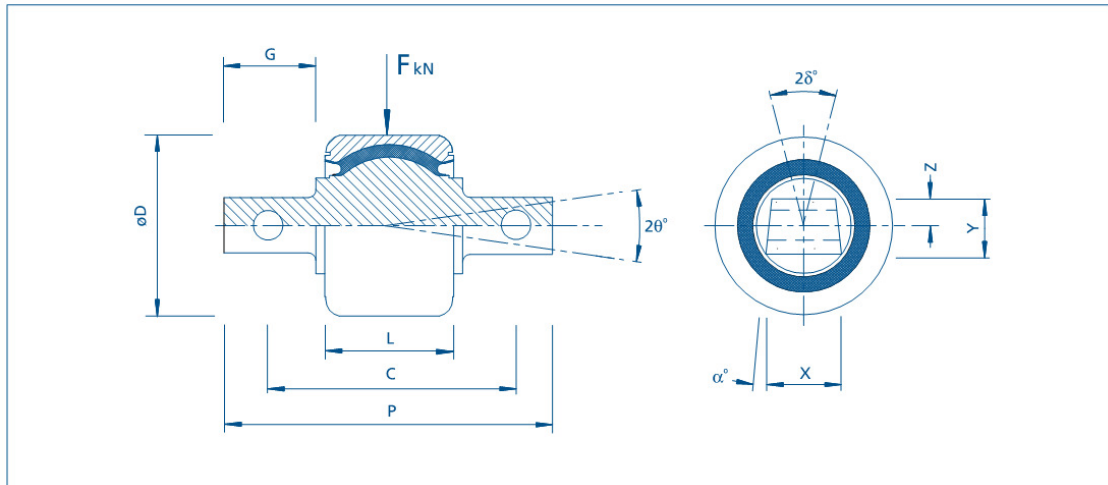

* Not a stock item – long lead times may apply

Part #	Dimensions (mm)									Radial		Torsional		Conical	
	D	L	X	Y	Z	α°	C	G	P	Normal Load (kN)	Stiffness (MN/m)	Normal Displacement (\pm°)	Stiffness (kNm/rad)	Normal Displacement (\pm°)	Stiffness (kNm/rad)
BJM3339*	67	53	23	22	9.5	5	N/A	22.5	104	35	70	6	1.3	8	1.7
BJM3341*	67	48	20	28	14	0	90	34	120	35	70	6	1.3	8	1.7
BJH094*	67	48	23	22	9.5	5	N/A	41	150	50	70	8	1.0	7	1.3
BJH093*	67	48	23	22	9.5	5	N/A	41	150	50	85	8	1.5	7	1.7
BJM3463*	90	65	34	34	17	11	N/A	42	160	50	70	8	2.0	6	2.5
BJM3458*	90	70	26	24	10	5	N/A	21	128	65	90	8	2.8	6	2.8
BJH045*	90	70	30	38	19	0	130	48	170	65	90	10	2.8	8	2.8
BJH095Q2*	90	70	30	38	19	0	130	48	170	65	90	10	2.8	8	2.8
BJH092Q1*	90	54	30	38	19	0	123	47	163	65	88	8	2.7	6	3.1

* Not a stock item – long lead times may apply

➤ Fitted Pin

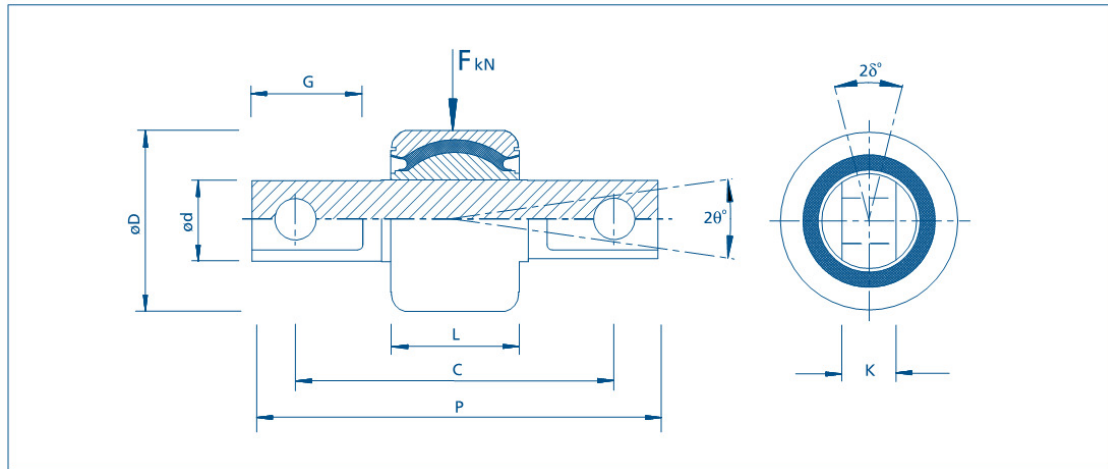

* Not a stock item – long lead times may apply

Assembly Part #	Joint Part #	Pin Part #	Dimensions (mm)							Radial		Torsional		Conical	
			D	L	d	C	G	K	P	Normal Load (kN)	Stiffness (MN/m)	Normal Displacement (±°)	Stiffness (kNm/rad)	Normal Displacement (±°)	Stiffness (kNm/rad)
BJ039*	BJ024	BJ039/18	66	48	25	90	33	21	120	50	70	8	1.0	7	1.3
BJM3468*	BJM3456	BJM3456/18	90	65	45	130	47	30	170	50	70	8	2.0	6	2.5
BJM3459*	BJM3469Q1	BJM3459/18	90	54	45	123	40	30	150	65	88	8	2.7	6	2.1
BJM3460*	BJM3469Q1	BJM3457/18	90	54	45	123	47	30	163	65	88	8	2.7	6	2.1
	BJM3469Q2	BJM3457/18	90	54	45	123	47	30	163	85	118	8	3.4	6	2.8
BJM3461*	BJM3469Q1	BJM3461/18	90	54	45	110	47	30	150	65	88	8	2.7	6	2.1
BJM3464*	BJM3469Q1	BJM3456/18	90	54	45	130	43	30	170	65	88	8	2.7	6	2.1
BJM3465*	BJM3469Q2	BJM3457/18	90	54	45	100	33	22	130	85	118	8	3.4	6	2.8
BJM3476*	BJM3469Q1	BJM3476/18	90	54	45	123	43	30	153	65	88	8	2.7	6	2.1
BJH070*	BJH069Q1	BJM3459/18	90	54	45	123	40	30	150	65	88	8	2.7	6	2.1
BJH071*	BJH069Q1	BJM3457/18	90	54	45	123	47	30	163	65	88	8	2.7	6	2.1
BJH072*	BJH069Q1	BJM3456/18	90	54	45	130	47	30	170	65	88	8	2.7	6	2.1
	85									118	8	3.4	6	2.8	
	45									60	8	2.0	6	1.5	
BJH073*	BJH069Q1	BJM3461/18	90	54	45	110	43	30	150	65	88	8	2.7	6	2.1
BJH074*	BJH069Q1	BJM3473/18	90	54	45	100	33	22	130	65	88	8	2.7	6	2.1
	BJH069Q2	BJM3473/18	90	54	45	100	33	22	130	85	118	8	3.4	6	2.8
BJH041*	BJH042	BJH041/18	127	102	55	165	50	38	215	120	130	10	9.0	7	11.0

* Not a stock item – long lead times may apply

Link Assemblies

Link assemblies with any of the above ball joints and bearings are available upon request.

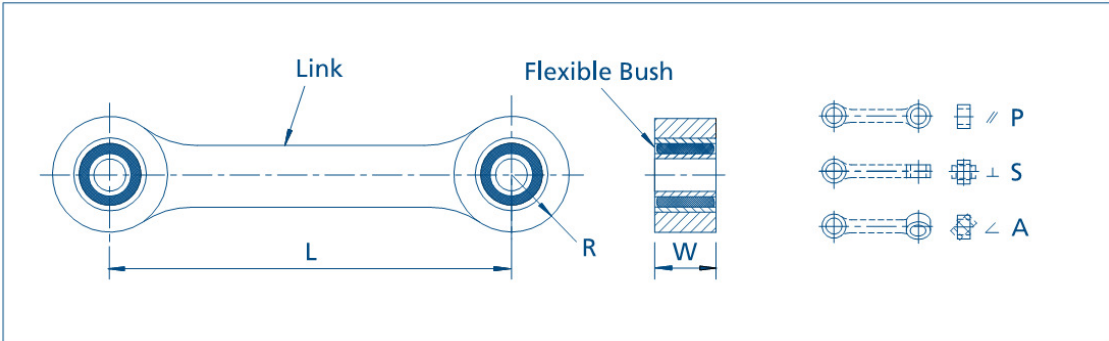
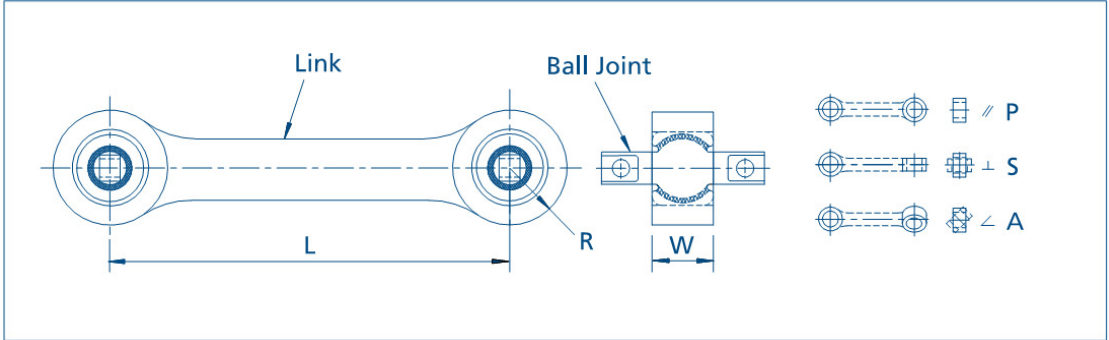

Shear - Compression Mounts / Plate Isolators

This compact mount is designed for heavy loads with the added feature of being able to accept a considerable amount of shear movement.

The Shear-Compression mount is designed so that the overall height is kept to a minimum. The height of the Shear-Compression mounts is 43.1mm which means that stability is kept to a maximum.

Ideally used in installations where larger than normal amplitude of displacement is experienced, such as vibratory shakers, vibratory feeders or where there is large equipment or structures to be isolated.

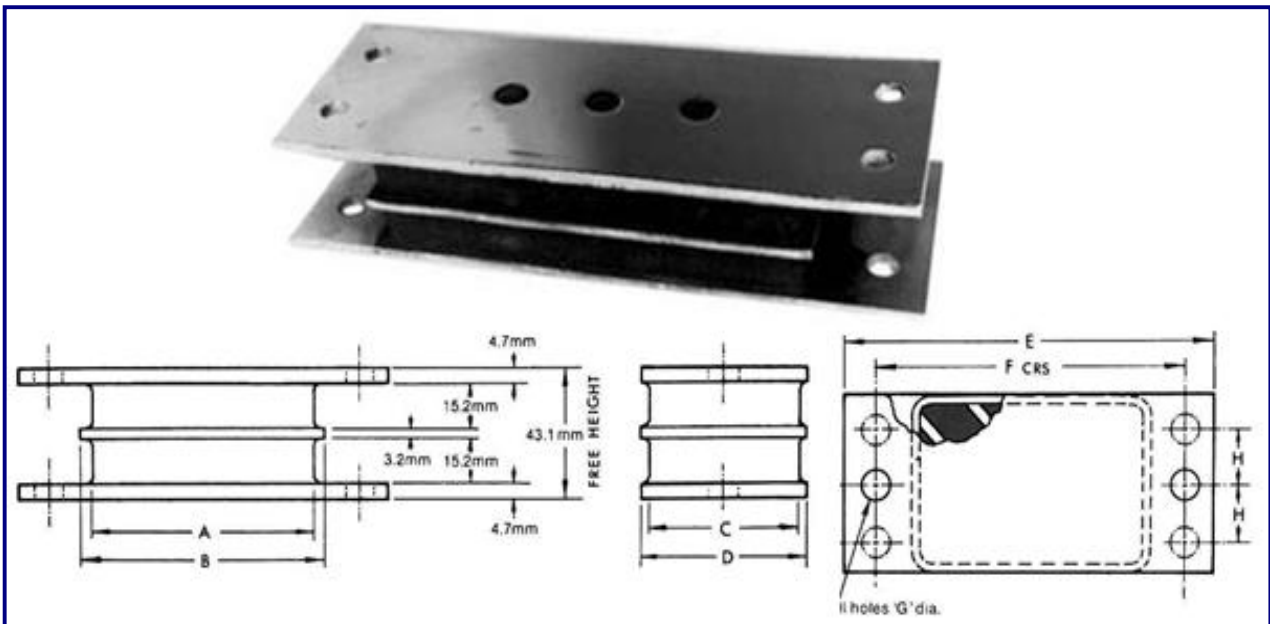

Parts AR7466/5-6-7 have four holes per plate (shown as dotted in the diagram) as opposed to the two holes per plate in the smaller units.

Part #	Dimensions (mm)							
	A	B	C	D	E	F	G	H
AR7466/1	57.2	63.5	50.8	57.2	108.0	88.9	10.3	-
AR7466/2	76.2	82.6	50.8	57.2	127.0	108.0	10.3	-
AR7466/4	120.7	127.0	50.8	57.2	168.3	146.1	10.3	-
AR7466/5	127.0	133.4	76.2	82.6	215.9	177.8	10.3	25.4
AR7466/6	152.4	158.8	101.6	108.0	250.8	209.6	13.5	25.4
AR7466/7	203.2	209.6	101.6	108.0	301.6	260.4	13.5	25.4

Part #	Compression		Shear	
	Normal Load (kg)	Deflection (mm)	Normal Load (kg)	Deflection (mm)
AR7466/1	408	4.6	50	7.4
AR7466/2	640	4.6	70	7.4
AR7466/4	1080	4.6	110	7.4
AR7466/5	1590	4.6	164	8.2
AR7466/6	2720	3.7	260	8.3
AR7466/7	3630	3.1	360	7.4

Shear-compression mounts can be used in inclined pairs to achieve the required compression & shear stiffness. The table below lists load ratings at various incline angles.

Incline Angle	AR7466/1		AR7466/2		AR7466/4		AR7466/5		AR7466/6		AR7466/7	
	Load (kg)	Deflection (mm)	Load (kg)	Deflection (mm)	Load (kg)	Deflection (mm)	Load (kg)	Deflection (mm)	Load (kg)	Deflection (mm)	Load (kg)	Deflection (mm)
0° Compr.	816	4.60	1280	4.60	2160	4.60	3180	4.60	5440	3.70	7260	3.10
5°	814	4.62	1276	4.62	2154	4.62	3170	4.62	5414	3.71	7230	3.11
10°	804	4.67	1262	4.67	2130	4.67	3136	4.67	5368	3.76	7162	3.15
15°	792	4.76	1240	4.76	2094	4.76	3082	4.76	5268	3.83	7034	3.21
20°	776	4.90	1214	4.90	2048	4.90	3014	4.90	5144	3.94	6860	3.30
25°	752	5.08	1178	5.08	1986	5.08	2920	5.08	4972	4.08	6638	3.42
30°	724	5.31	1132	5.31	1908	5.31	2806	5.31	4774	4.27	6374	3.58
35°	694	5.62	1084	5.62	1826	5.62	2680	5.62	4552	4.52	6060	3.78
40°	658	6.01	1028	6.01	1730	6.01	2536	6.01	4290	4.83	5726	4.05
45°	620	6.51	966	6.51	1624	6.51	2380	6.51	4008	5.23	5340	4.38
50°	580	7.16	902	7.16	1514	7.16	2212	7.16	3710	5.76	4938	4.82
60°	402	7.40	620	7.40	1032	7.40	1662	8.20	3066	7.40	4082	6.20
75°	180	7.40	268	7.40	424	7.40	684	8.20	1302	8.30	1832	7.40
90° Shear	100	7.40	140	7.40	220	7.40	328	8.20	520	8.30	720	7.40

- Loads are in kg and are per PAIR of mountings.
- Deflections are in mm and are total deflections.
- Load/deflection curve is not linear, interpolate with care.

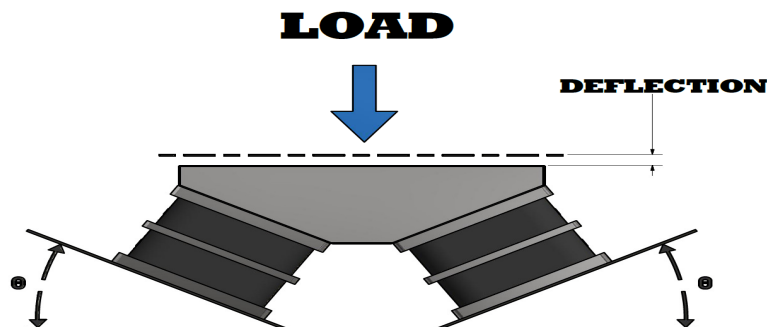

➤ Tolerances

Usual acceptable working range of the mounting is 60% to 110% of the normal load. Approximate deflections at loads other than normal can be approximated on a ratio basis. Tolerance on deflection is $\pm 20\%$.

Hyflex Flexible Couplings

Silentbloc Hyflex couplings, designed especially for Australian industrial applications, feature a patented Universal coupling bush as the flexible medium. The simple robust construction absorbs shock, torsional vibration and a reasonable degree of misalignment.



➤ Patented Universal Coupling Bush

In a Silentbloc coupling bush, positive grip of the rubber by the metal parts eliminates slip and wear. All relative movement takes place within the rubber body, which provides controlled deflection and ensures very long life.

Silentbloc flexible couplings, such as the Hyflex type, employ as their flexible medium the renowned patented Universal coupling bush. This is pressure bonded to the metal parts to eliminate sliding friction. The interference fit also effectively prevents entry of foreign matter. The result is a competitively priced coupling that provides:

- High flexibility.
- Long life without attention.
- Immunity to water, grit and other extreme conditions.

In all other couplings of either the single bush or multiple ring type, the bushes are a sliding fit in the bush half housing. Such a construction permits axial movement of the bush in operation, resulting in wear which allows the ingress of abrasive matter and, in many cases, necessitates frequent replacement of the bushes.

Standard Hyflex couplings are suitable for operating temperatures up to 66°C (150°F).

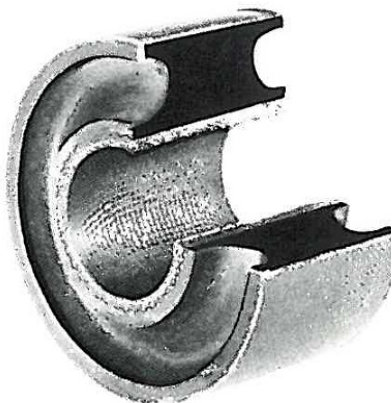

- (a) Bush compressed into housing
- (b) High shock-absorbing, fatigue resistant rubber. End cavities designed to provide uniform stress distribution
- (c) Steel wire mesh bonded to the rubber by penetration and vulcanisation under pressure
- (d) High-tensile bolt with self-locking nut
- (e) Steel trunnion sleeve driven into the reinforced bore of the bush
- (f) Bush reinforced with fabric bonded into the rubber

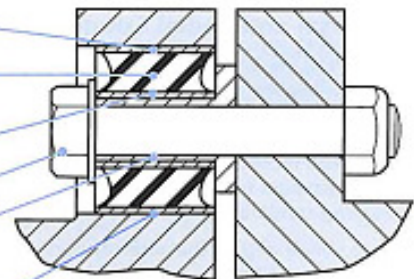

➤ Selection Procedure

For correct coupling selection the following information is required:

- Power or torque to be transmitted
- Speed of shafts to be coupled
- Prime mover type (eg: electric motor, 6 cylinder diesel engine etc.)
- Driven machine characteristics (eg: uniformly loaded conveyor, multi-cylinder air compressor etc.)
- Any excessive starting, stalling or braking torque
- Shaft diameters and keyway dimensions
- The distance between shaft ends
- Any space limitations caused by other equipment
- Any unusual temperature conditions

Once the above are known, the following procedure should be observed to select a suitable Hyflex coupling:

1. Select type of coupling required (complete coupling or bush half only)
2. Select suitable service factor from
3. Determine required coupling capacity in kW per 100rpm
4. Select coupling by kW/100rpm capacity required
5. Check that selected coupling meets dimensional requirements, maximum speed, axial thrust and misalignment requirements

➤ Speed Change Devices

A wide range of devices, such as gear boxes of numerous types, vee belt drives, etc., are available to permit a change in the relative speed along a drive-train. In considering the effect that these devices have upon coupling selections, the basic axioms are:

1. Speed change devices are torque multipliers (the increase torque as they decrease speed, decrease torque as they increase speed).
2. Speed change devices do not change horsepower (apart from friction losses, etc., they do not alter the total amount of work done, only the way in which it is being done).

For many applications it is satisfactory to assume that the power lost in driving the speed change device components is negligible, but in the following cases some allowance for hp reduction may be necessary:

1. Reduction greater than 40:1
2. Reduction through friction type variable speed drives
3. Application with original power in excess of 750kW

In such cases actual figures for losses should be obtained from the speed change device manufacturer, as losses vary considerably for only slightly differing types of device. These losses will generally be expressed as a percentage efficiency, and original power may be corrected as follows:

$$\text{Output Power} = \frac{\text{Input Power}}{100} \times \text{Percentage Efficiency}$$

In cases where a number of ratios is available in one device (eg: as in an automobile gearbox), the coupling capacity should be calculated for the lowest gearbox output speed (the largest ratio in a speed decrease device, or the smallest ratio in a speed increase device).

➤ **Axial Thrust**

The Hyflex coupling is not designed to withstand axial thrust, and for installations where significant axial thrust will be encountered a Radial Thrust Coupling or a specially modified coupling will be required. In some installations however, very light intermittent or permanent axial thrust occurs (eg: in some vertical shaft applications), and the product tables set out maximum safe thrust figures for Hyflex couplings. Application for any length of time of loads in excess of those listed below may lead to bush disassembly.

➤ **Maximum Speed**

The maximum operating speed of a coupling is limited by the ability of the material used in its flanges to resist centrifugal stresses. This ability is determined partly by the tensile strength of the material, partly by the shape of the coupling, and to a lesser degree by some other factors. Since excessive coupling speed may result in the rupture of the material at the coupling periphery, leading to sudden and possibly disastrous disintegration of the coupling, maximum speeds quoted for couplings are normally calculated allowing substantial safety margins.

The maximum operating speed listed in the product tables assumes moderate shock loading and constant speed operation, and of course assume that the coupling is in unmarked condition; and should be adjusted as follows:

1. For variable speed motors, eg: ungoverned petrol engines, where over-revving is possible, reduce figures by 10%
2. For drives encountering severe shock loads, reduce figures by 5%

➤ **Bore Dimension and Tolerances**

Silentbloc couplings are normally supplied with a pilot hole suitable for machining to the minimum bore diameter indicated in the product tables. This pilot holes is not necessarily concentric and should not be used as a register for re-boring.

When couplings are being bored, ensure that they are concentric and square so that the coupling will run true with the shafts. Hyflex couplings should be bored true to the outside diameter of the flange.

All couplings are suitable for the maximum nominated bore, provided a British Standard rectangular parallel key is used. A square key is permissible with the maximum nominated bore on some occasions when full rated power is not being transmitted.

If required couplings can be supplied with the bore machined to your specifications.

➤ Fitting and Alignment

Every effort should be made to obtain and maintain good alignment between the shafts of connected machines. This will minimise loading of shaft bearings and retain full coupling flexibility to absorb future misalignment due to settling, wear, temperature effects, vibration, shock or cyclic variation in the load.

Figure 8 and Figure 9 show the recommended maximum degree of allowable misalignment for Hyflex couplings.

Parallel Misalignment
Gap 'A' to be maximum of .005mm per mm diameter of shaft

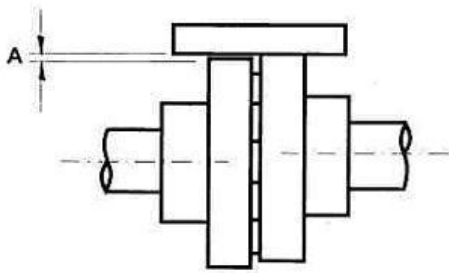

Figure 8: Parallel Misalignment

Angular Misalignment
Maximum difference between B1 and B2 on any diameter to be .004mm per mm diameter of coupling

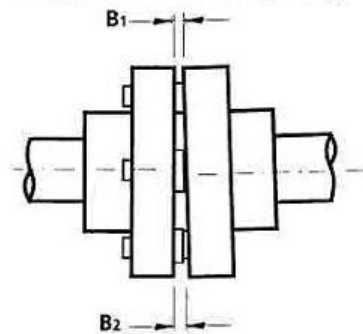

Figure 9: Angular misalignment

For example, for an HF146 coupling (140mm diameter) with a 38mm shaft, the allowable misalignments would be:

Parallel: 0.19mm maximum gap
Angular: 0.56mm maximum difference



➤ **Service Factors**

Table 3: Coupling service factors

Type of Drive	Electric Motor or Turbine	Steam & Petrol Engines (6+ Cylinders)	Steam & Petrol Engines (2-5 Cylinders)	Diesel Engines (6+ Cylinders)	Diesel Engines (3-5 Cylinders) or Single Cylinder Petrol Engines	Diesel Engines (1-2 Cylinders)						
Centrifugal Pumps (Steady Load)	1.0	1.5	2.0	2.0	2.5	3.5						
Exciters												
Fans & Blowers (Light Duty)												
Generators (Steady Load)												
Rotary Compressors (Steady Load)	1.25	2.0	2.5	2.5	3.0	4.0						
Brewing and Bottling Machinery												
Centrifugal Pumps (Fluctuating Load)												
Conveyors & Elevators (Uniformly Loaded)												
Liquid Agitators (Unbaffled)	1.5	2.5	3.0	3.0	3.5	4.5						
Agitators & Mixers (Baffled)												
Conveyors & Elevators (Non-Uniform Loads)												
Fans & Blowers (Medium Duty)												
Generators (Pulsating Load)												
Kilns (Small & Medium)												
Medium Machine Tools												
Pumps (Hydraulic, Geared & Vane)												
Rotary Compressors (Fluctuating Load)												
Textile Machinery												
Woodworking Machinery												
Air Compressors (Multi-Cylinder)							2.0	3.0	3.5	3.5	4.0	5.0
Conveyors – Shuttle												
Cranes & Hoists (Light Duty)												
Kilns (Large & Heavy Duty)												
Mills, Cement												
Mills, Copper & Brass Rolling												
Mills, Paper Equipment												
Mills, Pug, Ball & Rod												
Presses, Punch & Forming												
Pumps (Multi Cylinder)												
Pumps (Vacuum)												
Shears & Guillotines)												
Ship Propulsion												
Sugar Crushing Rolls												
Welding Plant												
Air Compressors (Single Cylinder)												
Dredge Drives												
Drilling Rigs												
Hoists (Medium Duty)												
Machine Tools (Heavy)												
Mine Fans & Heavy Blowers												
Mining Machinery												
Rubber Mills												
Rubber Mixers & Crackers												
Sawmill Equipment												
Conveyors (Reciprocating, Vibrating)							3.0	4.0	4.5	4.5	5.0	6.0
Cooling Towers												
Cranes (Slewing & Travelling)												
Crushers (Ore & Stone)												
Drop Hammers												
Pumps (Single Acting)												
Steel Making												
Steel Rolling Mills												
Steel Shears & Croppers												
Tube Mills												
Cranes (Hoisting)	3.5	4.5	5.0	5.0	5.5	6.5						

➤ Coupling Dimensions

▪ Complete Couplings

N denotes the number of bushes per complete assembly.

Part #	N	Dimensions (mm)								Approx Net Weight Min Bore (kg)
		D	L	G	W	V	H	K	P	
HF102	2	89	79	2.4	15	11	48	51	61.9	2
HF104	4									2
HF132	2	114	92	3.2	18	11	70	70	81.0	4
HF134	4									4
HF143	3	140	105	4.8	22	15	70	76	101.6	6
HF144	4									6
HF146	6									6
HF204	4	165	144	4.8	25	18	86	92	120.7	11
HF208	8									10
HF244	4	210	170	4.8	29	21	106	121	152.4	20
HF248	8									19
HF304	4	260	208	4.8	33	28	133	156	193.7	39
HF308	8									37
HF343	3	298	222	6.4	40	29	152	178	217.5	54
HF346	6									52
HF404	4	330	260	6.4	40	29	178	206	247.7	72
HF408	8									70
HF464	4	419	298	6.4	49	32	229	267	317.5	151
HF468	8									145
HF545	5	483	362	6.4	53	32	254	292	368.3	211
HF5410	10									205
HF645	5	533	384	9.5	59	38	292	311	406.4	283
HF6410	10									277
HF716	6	610	416	9.5	59	38	330	349	469.9	412
HF7112	12									393

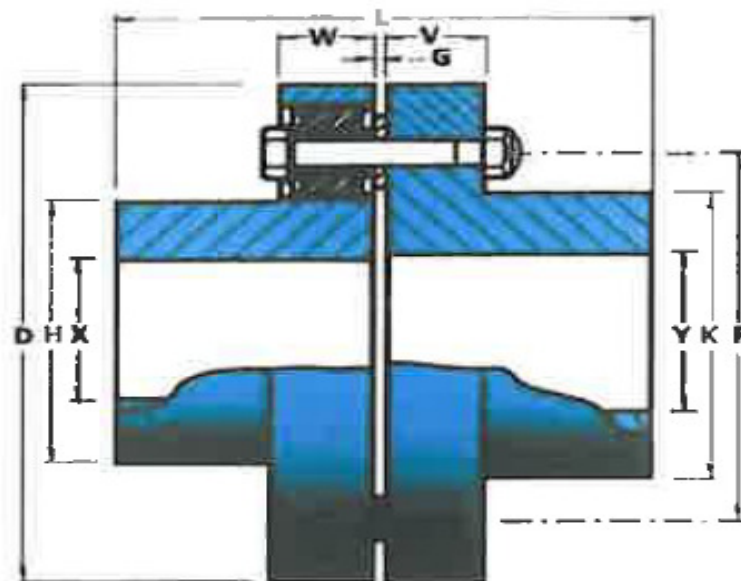

Bush Half

Bolt Half

- **Bush Halves**

The Hyflex bush half only may be used where a drive is to be taken from an existing flange or flywheel, resulting in a simple, economical and space saving installation.

N denotes number of bushes per complete assembly.

Part #	N	Dimensions (mm)						Approx Net Weight Min Bore (kg)
		D	L	G	W	H	P	
HFH102	2	89	38	2.4	15	48	61.9	1.0
HFH104	4							1.0
HFH132	2	114	44	3.2	18	70	81.0	2.0
HFH134	4							2.0
HFH143	3	140	51	3.2	22	70	101.6	3.1
HFH144	4							3.0
HFH146	6							2.9
HFH204	4	165	70	4.8	25	86	120.7	5.4
HFH208	8							5.0
HFH244	4	210	83	4.8	29	106	152.4	9.7
HFH248	8							8.8
HFH304	4	260	102	4.8	33	133	193.7	18.0
HFH308	8							16.5
HFH343	3	298	108	6.4	40	152	217.5	25.3
HFH346	6							24.0
HFH404	4	330	127	6.4	40	178	247.7	35.0
HFH408	8							32.0
HFH464	4	419	146	6.4	49	229	317.5	68.0
HFH468	8							61.0
HFH545	5	483	178	6.4	53	254	368.3	94.0
HFH5410	10							82.0
HFH645	5	533	187	9.5	59	292	406.4	128.0
HFH6410	10							110.0
HFH716	6	610	203	9.5	59	330	469.9	176.0
HFH7112	12							152.0

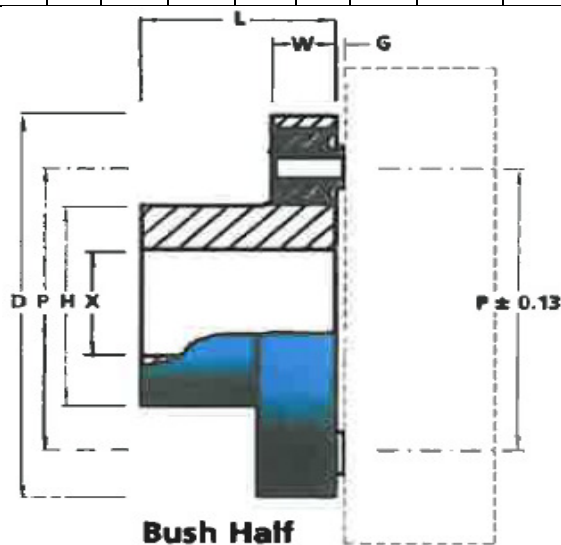

➤ Capacities

Design data for complete couplings and bush halves is provided in the capacities table on this page.

Complete Coupling Part #	Bush Half Part #	kW per 100 RPM	Bush Half Bore X (mm)		Bolt Half Bore Y (mm)		Max Speed (RPM)	Torque Capacity (Nm)	Max Axial Thrust (N)
			Max	Min	Max	Min			
HF102	HFH102	0.3	25	-	29	-	11040	28	44
HF104	HFH104	0.6						56	89
HF132	HFH132	0.5	35	-	38	-	8580	48	89
HF134	HFH134	1.0						96	178
HF143	HFH143	1.3	38	16	45	16	7020	124	267
HF144	HFH144	1.7						162	356
HF146	HFH146	2.6						248	533
HF204	HFH204	2.6	51	22	57	22	5940	248	533
HF208	HFH208	5.2						496	1067
HF244	HFH244	4.5	64	25	73	25	4680	429	356
HF248	HFH248	9.0						858	711
HF304	HFH304	9.4	76	38	92	38	3770	897	356
HF308	HFH308	18.8						1794	711
HF343	HFH343	14.2	89	44	105	44	3290	1355	467
HF346	HFH346	28.4						2710	933
HF404	HFH404	18.7	102	51	124	51	2970	1784	622
HF408	HFH408	37.4						3568	1245
HF464	HFH464	37.4	121	51	153	51	2340	3568	1245
HF468	HFH468	74.8						7136	2489
HF545	HFH545	63.4	140	64	175	64	2030	6050	2223
HF5410	HFH5410	126.8						12100	4445
HF645	HFH645	100.7	165	76	184	76	1840	9609	2223
HF6410	HFH6410	201.4						19218	4445
HF716	HFH716	138.0	181	102	204	102	1610	13168	2667
HF7112	HFH7112	276.0						26336	5334

- **Spare Parts**

Trunnion and rubber components are available individually or ready assembled.

- ✓ **Hyflex Rubber/Trunnion Assemblies**

Part #	Used On
HFRT10	HF102, HF104
HFRT13	HF132, HF134
HFRT14	HF143, HF144, HF146
HFRT20	HF204, HF208
HFRT24	HF244, HF248
HFRT30	HF304, HF308
HFRT40	HF343, HF346, HF404, HF408
HFRT46	HF464, HF468
HFRT54	HF545, HF5410
HFRT64	HF645, HF6410
HFRT71	HF716, HF7112

- ✓ **Universal Rubber/Trunnion Assemblies**

Part #	Used On
UCRT25	UC25
UCRT30	UC30
UCRT35	UC35
UCRT40	UC40
UCRT50	UC50
UCRT60	UC60
UCRT70	UC70
UCRT80	UC80
UCRT90	UC90
UCRT100	UC100
UCRT120	UC120

✓ Hyflex Trunnions

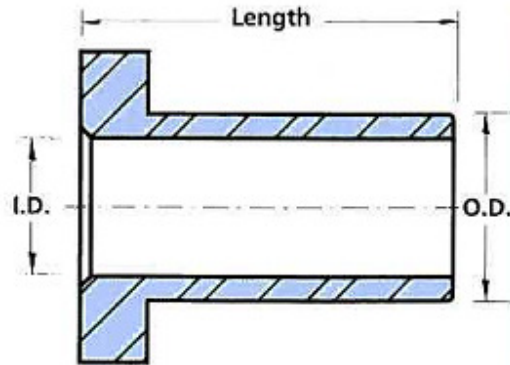

Hyflex Trunnion

Part #	Used On	Nominal Dimensions (mm)		
		OD	ID	Length
HF102/3	HF102, HF104	10.0	6.5	15.2
HF132/3	HF132, HF134	10.0	6.5	19.2
HF143/3	HF143, HF144, HF146	11.5	8.1	22.4
HF204/3	HF204, HF208	13.0	9.7	27.0
HF244/3	HF244, HF248	16.2	11.3	30.2
HF304/3	HF304, HF308	17.9	12.9	36.4
HF404/3	HF343, HF346, HF404, HF408	27.4	14.5	42.6
HF464/3	HF464, HF468	34.7	16.3	55.6
HF545/3	HF545, HF5410	35.8	19.5	58.3
HF645/3	HF645, HF6410, HF716, HF7112	48.6	26.2	67.4

✓ Universal Trunnions

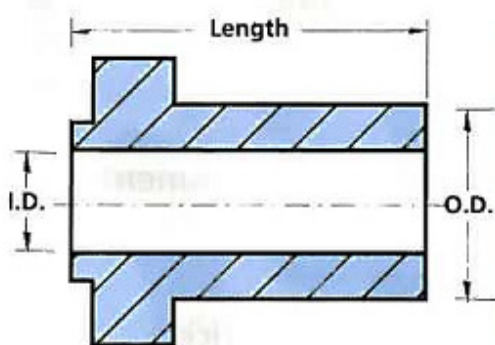

Universal Trunnion

Part #	Used On	Nominal Dimensions (mm)		
		OD	ID	Length
FC1126	UC25	10.0	6.5	17.5
FC1127	UC30	10.0	6.5	22.2
FC1128	UC35	11.5	8.1	26.2
FC1129	UC40	13.0	9.7	35.6
FC1130	UC50	16.2	11.3	38.1
FC1131	UC60	17.9	12.9	48.4
FC1132	UC70	27.4	14.7	51.6
FC1133	UC80	30.7	14.7	59.6
FC1134	UC90	34.7	16.3	67.4
FC1135	UC100	35.8	19.5	70.2
FC1136	UC120	48.6	26.2	81.4

✓ **Rubber Bushes**

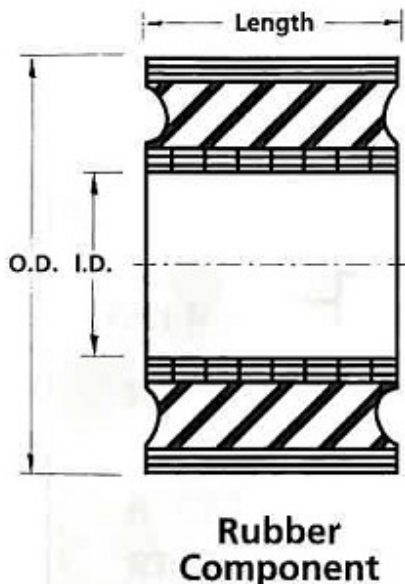

Part #	Used On		Nominal Dimensions (mm)		
	Universal	Hyflex	OD	ID	Length
FC1149	UC25	HF102, HF104	20.5	9.5	13.0
FC1150	UC30	HF132, HF134	25.0	9.5	16.0
FC1151	UC35	HF143, HF144, HF146	29.0	11.0	20.0
FC1152	UC40	HF204, HF208	35.0	12.5	21.5
FC1153	UC50	HF244, HF248	45.0	16.0	25.0
FC1154	UC60	HF304, HF308	53.0	17.5	31.5
FC1156	UC70	HF343, HF346, HF404, HF408	65.0	27.0	35.0
FC1157	UC80		73.5	30.0	42.5
FC1158	UC90	HF464, HF468	82.0	34.0	49.5
FC1159	UC100	HF545, HF5410	91.0	35.0	52.0
FC1160	UC120	HF645, HF6410, HF716, HF7112	108.0	47.5	57.5

Wheel Chocks & Hose Ramps

The Silentbloc range of wheel chocks and hose ramps are essential tools for safety conscious vehicle operators and workshops. Silentbloc wheel chocks are easy to use, of robust design and available in a variety of sizes.

A rope handle is standard on all wheel chocks

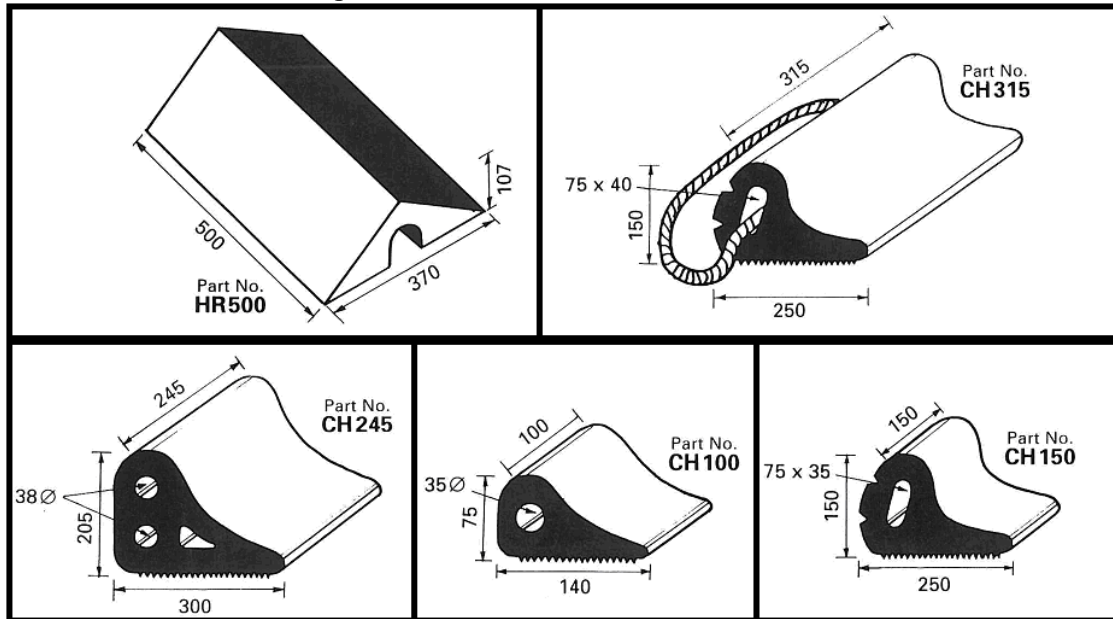

Vibration Control Pads

A simple and extremely economical method of effectively controlling machinery vibration, shock and acoustic noise. Moulded from rubber with a cross ribbed section, Silentbloc vibration control pads act as energy absorbers, enabling large, horizontal forces to be generated without slipping or walking occurring. They can substantially reduce structure borne acoustic noise caused by vibration being transmitted in sheet metal components, pipes, ducts, beams, walls and floors. They can be used on the floor, wall or ceiling.

Made from oil-resistant elastomer, they are supplied in 380x380mm sheets 10mm thick before loading. The sheets can be easily and quickly cut to the required size with a sharp knife or hand shears.

For optimum performance, the standard pads should be loaded at 350kPa (3.6kg/cm²). The pad can usually be cut out to follow the contour of the mounting feet. Because the pads absorb the horizontal vibration, it is not, in most instances, necessary to tie the machine down, however, it is wise to leave a 7mm overlay around the feet of the machine. If bolting is required, rubber tubing and steel washers should be used to prevent any transmission path for the vibration. If the weight of the machine is not evenly distributed, the pads should be sized and placed according to the machinery weight distribution.

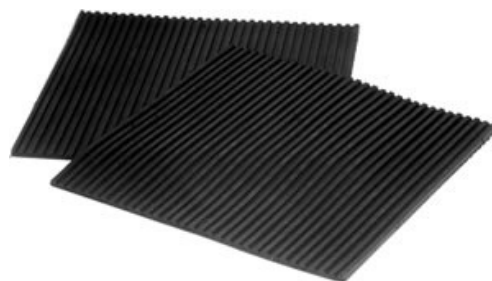
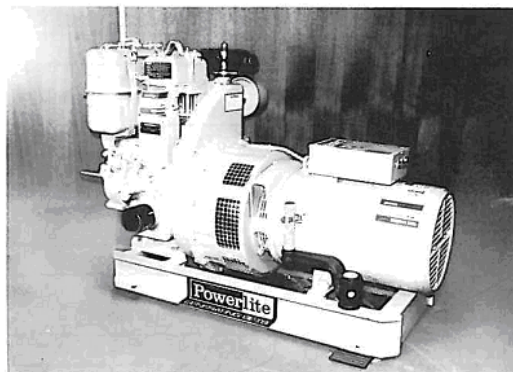
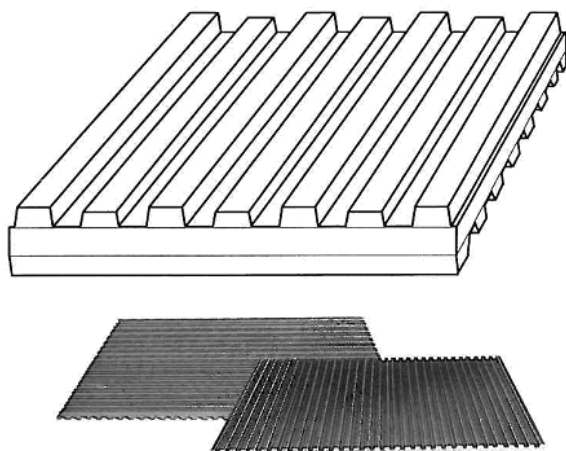

Part #	Normal Load (kg)
VPC1	5200

Rubber Extrusions

Motherson Elastomers Pty Ltd is a vertically integrated manufacturer, we can conceive, design, develop, engineer and manufacture products tailored to suit your specific requirements.

Extrusions can include options such as

- Wire carriers
- Date Coding
- Heat bonded taping
- Tabbing
- Normec splicing
- Plasma surface treatments
- Coatings
- Vent hole drilling
- Spray painting
- Cold splicing
- TPE corner joining

A sample of Motherson extruded products:



Moulding Capabilities

With injection and compression moulding facilities, we can as a vertically integrated manufacturer, can conceive, design, develop, engineer and manufacture products tailored to suit your specific requirements such as:

- Suspension bushes
- Engine & transmission mounts
- Bump stops
- Large engine gaskets
- Dust covers
- Wheel Chocks

Our engineering department can design and manufacture your specific tooling requirements.

A sample of Motherson moulded products:





Silentbloc®

Customer Service & Manufacturing Plant
Phone: +61 3 5440 2069

Motherson Elastomers Pty Limited

Proud to be part of samvardhana 

MEPL

Customer Service

48-86, Powell Street
Bendigo, Victoria, 3550, Australia
PH: +61 3 5440 2069
Fax: +61 3 5443 1661

HEAD OFFICE

Unit 4, 18-22, Lexia Place
Mulgrave, Victoria, 3170 Australia
PH: +61 3 8561 7900
Fax: +61 3 8561 7999

ABN: 19 124 112 009

ACN: 124 112 009